

WATERAX 
WE MOVE WATER

WATERAX VEHICLE-MOUNT PUMP SOLUTIONS

Compact. Reliable. Engineered for Wildland Firefighting.

Purpose-built for OEMs designing brush trucks, UTV skids, Type 4–7 apparatus, and wildland firefighting vehicles.

We Move Water. You Build What Saves Lives.

ENGINEERED FOR OEM INTEGRATION

WATERAX delivers a complete lineup of compact, high-pressure, vehicle-mount fire pumps trusted by wildland firefighters across North America and around the world. Our pumps offer the perfect balance of pressure, flow, weight, and durability—making them ideal for slip-ons, rapid-attack units, municipal support vehicles, and Type 4–7 apparatus.

Backed by over a century of innovation, our pump platforms provide OEMs with:

- Compact, high-pressure pump platforms tailored to wildland operations
- Reliable, proven performance in demanding wildland environments
- Flexible configurations for a variety of apparatus types
- Low-maintenance designs with quick-release systems that reduce downtime and lifecycle cost
- Trusted support, training, and parts availability across North America

WHY WATERAX

Designed for Firefighters. Built for OEMs.

High-Pressure Performance in Small Footprints

Ideal for lightweight brush trucks and rapid-deployment skids.

High-Pressure, Compact Platforms

Purpose-designed for Type 6/7 trucks, UTVs, and lightweight wildland apparatus.

Quick-Release Pump Ends

Reduce service time and keep your vehicles in operation longer.

Interchangeable Pump Heads

Shared components across platforms significantly lower inventory costs.

Corrosion-Resistant Engineering

Anodized aluminum impellers and sealed bearings for long-term durability.

Proven in North America's Toughest Wildfires

WATERAX pumps are trusted by federal, state, and municipal agencies throughout the USA and internationally.

OEM-Friendly Support

Complete spec sheets, CAD drawings, wiring diagrams, installation guidance, and dealer/OEM technical support.

The **BB-4-D902** & **BB-4-23V** are purpose-built for wildland fire operations, delivering reliable performance in demanding conditions. It is certified for the Type 6 Fire Engine Model 643P & 643U specifications, making it a dependable solution for agency-specified Type 6 applications.

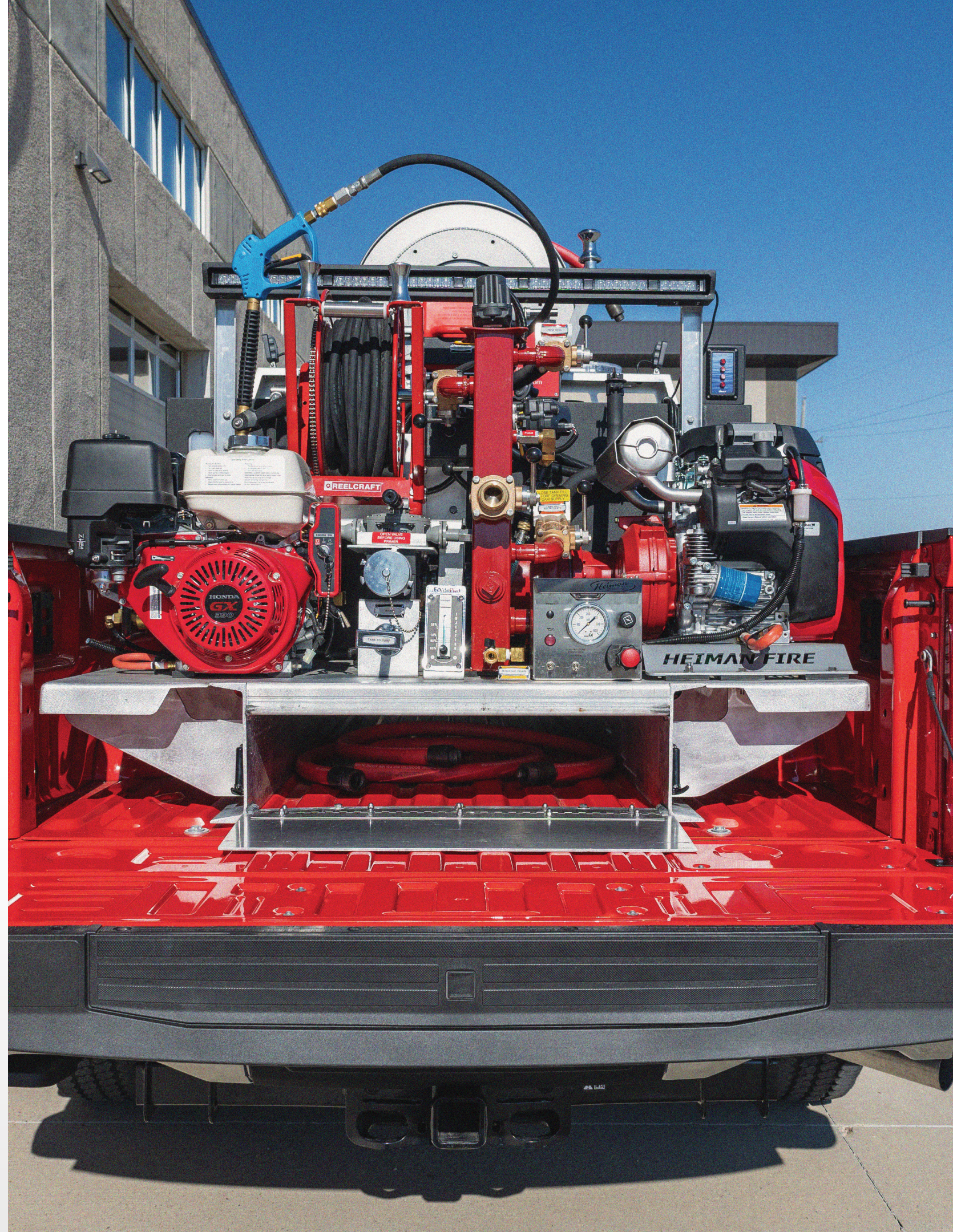
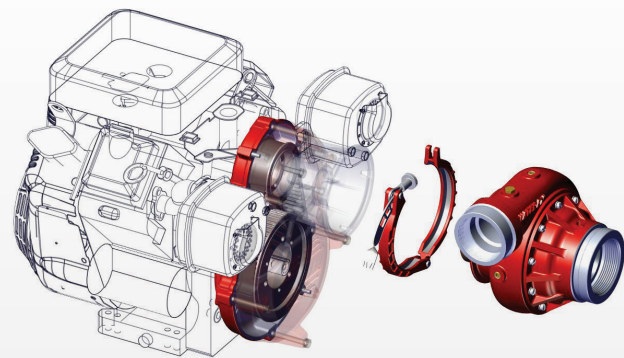
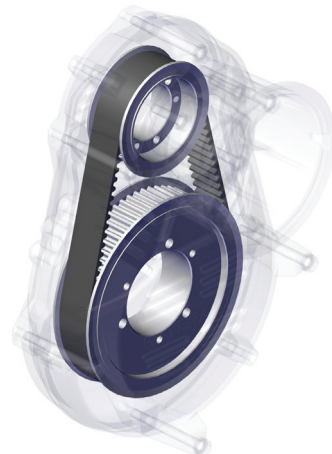
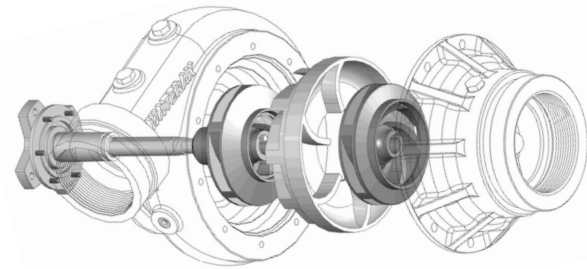

BB-4® SERIES

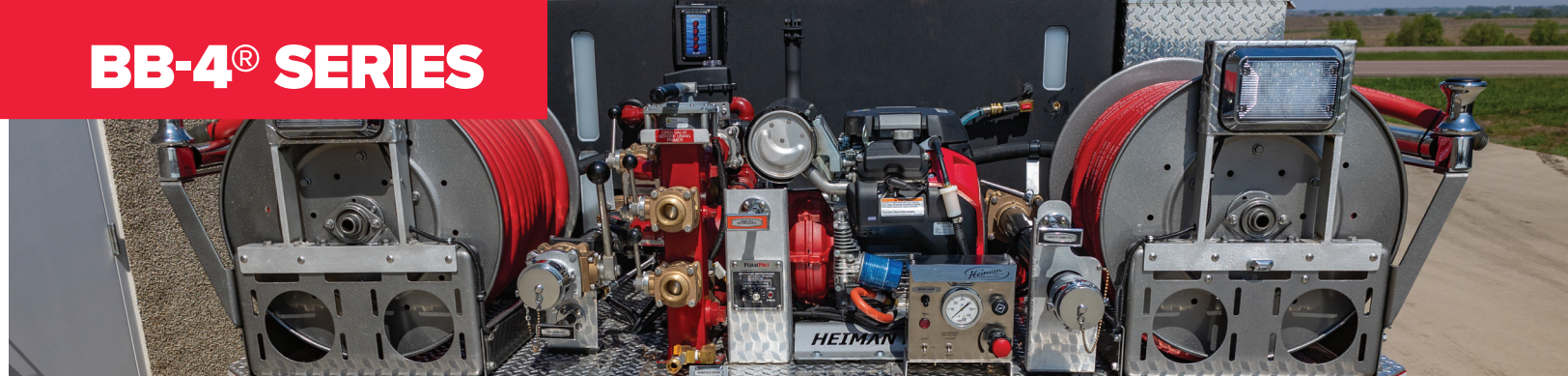

High-Pressure, 4-Stage Pumps for Type 6 Brush Trucks

The **BB-4®** gasoline series delivers legendary high-pressure performance trusted by forestry agencies for decades. Ideal for slip-ons, direct attack, remote water supply, and structure protection.

Interchangeable with **MARK-3®** 185cc pump heads for reduced spare-part complexity.

Models:

- 100025 – BB-4-18V (B&S18 / 4-Stage)
- 100028 – BB-4-23V (B&S23 / 4-Stage)
- 100032 – BB-4-21H (Honda GX630 / 4-Stage)
- 100161 – BB-4-25H (Honda IGX800 EFI / 4-Stage)

High pressure, proven reliability, shared components, longtime wildland standard.

B2X™ SERIES

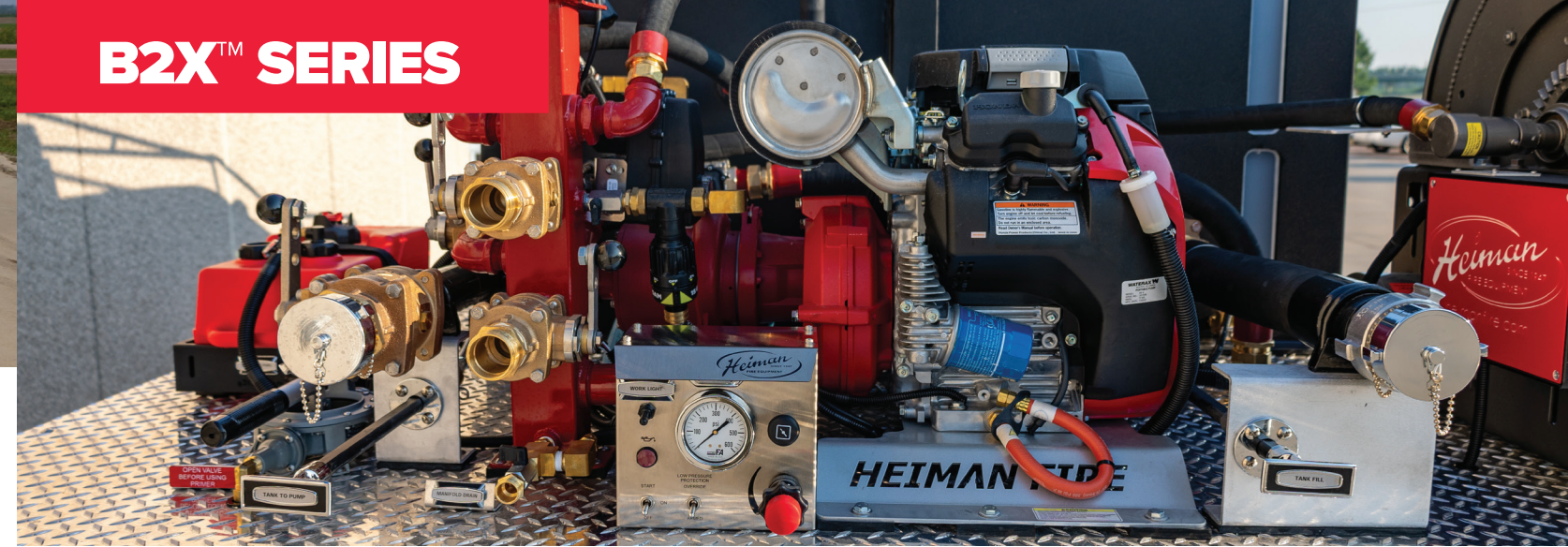

Mid-Range Pump for Dual-Line Attack & Water Transfer

The **B2X™** gasoline series combines volume and pressure, making it ideal for WUI operations, slip-on modules, and UTV/Type 5–7 apparatus. A low-maintenance belt-drive system ensures dependable service.

Models:

- 100055 – B2X-18V (B&S18 / 2-Stage)
- 100072 – B2X-23V (B&S23 / 2-Stage)
- 100162 – B2X-25H (Honda IGX800 EFI / 2-Stage)

Balanced performance, ideal for multipurpose wildland/urban interface rigs, economical operation.

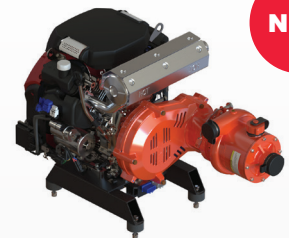

NEW

BB-4-25H

Honda IGX800 EFI



Flow rate at specified pressure
Maximum pressure: **470 PSI** (32.4 bar)
Free flow: **109 US gal/min** (413 L/min)
Maximum head: **1084.4'** (330.5 m)

Item no: **100161**

The new **BB-4-25H** vehicle-mounted pump features the 24.8 HP HONDA IGX800 EFI engine, delivering best-in-class performance and full DCP compatibility in both single and dual control panel configurations. The engine speed can be controlled via the DCP directly through the engine ECU, without the need for an additional throttle actuator.

Flow		Pressure		
US GPM	L/min	PSI	Bar	
105	397	@	150	10.3
96	363	@	250	17.2
74.2	280.5	@	350	24.1

Compatible with DCP



BB-4-18V

B&S Vanguard™



Item no: **100025**

The **BB-4-18V** is configured for vehicle mounting with an 18 HP Briggs & Stratton engine, vertical-drive unit, FastWire cable with 8-pin connector, and remote-mount control panel.

Flow rate at specified pressure
Maximum pressure: **440 PSI** (30.3 bar)
Free flow: **104 US gals/min** (394 L/min)
Maximum head: **1016'** (310 m)

Flow		Pressure		
US GPM	L/min	PSI	Bar	
100	379	@	150	10.3
80	303	@	250	17.2
50	189	@	350	24.1



BB-4-23V

B&S Vanguard™



Item no: **100028**

The **BB-4-23V** configuration is ready for vehicle mounting with a 23 HP Briggs & Stratton engine, vertical drive unit and FastWire cable 8-pin connector.

Flow rate at specified pressure
Maximum pressure: **440 PSI** (30.3 bar)
Free flow: **106 US gals/min** (401 L/min)
Maximum head: **1016'** (310 m)

Flow		Pressure		
US GPM	L/min	PSI	Bar	
105	397	@	150	10.3
95	360	@	250	17.2
65	246	@	350	24.1



BB-4-21H

Honda GX630



Item no: **100032**

The **BB-4-21H** model is designed with a 21 HP Honda engine with a vehicle-base mount, horizontal-drive unit, FastWire cable with 8-pin connection, and remote-mount control panel.

Flow rate at specified pressure
Maximum pressure: **440 PSI** (30.3 bar)
Free flow: **106 US gals/min** (401 L/min)
Maximum head: **1016'** (310 m)

Flow		Pressure		
US GPM	L/min	PSI	Bar	
103	390	@	150	10.3
94	356	@	250	17.2
65	246	@	350	24.1



NEW

B2X-25H

Honda IGX800 EFI



Item no: **100162**

The new **B2X-25H** mid-range pump is powered by the 24.8 HP HONDA IGX800 EFI engine, delivering an impressive 150 GPM at 150 PSI. It is fully compatible with the DCP, supporting both single and dual control panel configurations. The engine speed can be controlled via the DCP directly through the engine ECU, without the need for an additional throttle actuator.

Flow rate at specified pressure
Maximum pressure: **210 PSI** (14.8 Bar)
Free flow: **300 US gals/min** (1136 L/min)
Maximum head: **484'** (148 m)

Flow		Pressure		
US GPM	L/min	PSI	Bar	
278	1051	@	50	3.4
233	881	@	100	6.9
155	586	@	150	10.3

Compatible with DCP



B2X-18V

B&S Vanguard™



Item no: **100055**

The **B2X-18V** is powered by an 18 HP Briggs & Stratton engine with a vertically-mounted drive unit and configured with a vehicle base mount and 8-pin FastWire connections.

Flow rate at specified pressure
Maximum pressure: **190 PSI** (13.3 bar)
Free flow: **300 US gals/min** (1136 L/min)
Maximum head: **439'** (134 m)

Flow		Pressure		
US GPM	L/min	PSI	Bar	
261	988	@	50	3.4
150	568	@	100	6.9
65	246	@	150	10.3



B2X-23V

B&S Vanguard™



Item no: **100072**

The **B2X-23V** is powered by a 23 HP Briggs & Stratton engine and configured with a vehicle-base mount, 8-pin FastWire connections and vertical-drive unit.

Flow rate at specified pressure
Maximum pressure: **200 PSI** (13.8 bar)
Free flow: **300 US gals/min** (1136 L/min)
Maximum head: **462'** (141 m)

Flow		Pressure		
US GPM	L/min	PSI	Bar	
288	1090	@	50	3.4
200	757	@	100	6.9
95	360	@	150	10.3

STRIKER™ SERIES

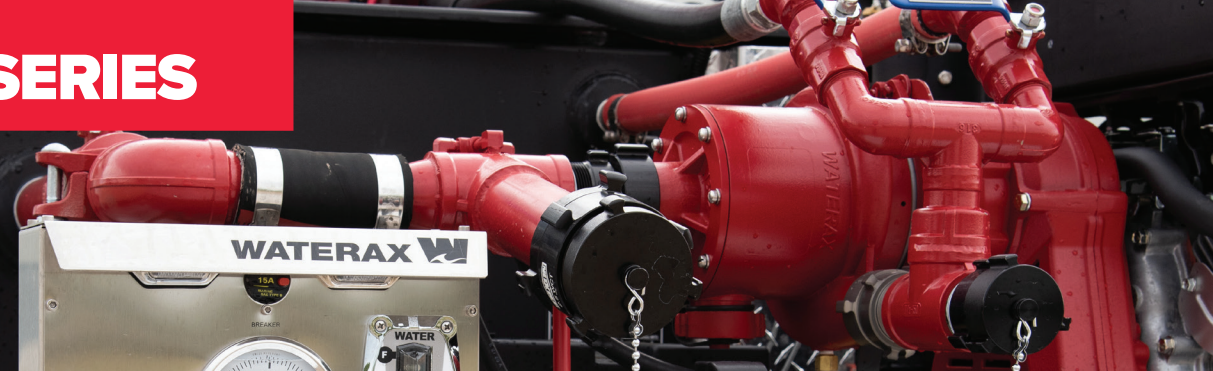

High-Pressure Multi-Stage Pumps for Brush Trucks

STRIKER™ pumps deliver excellent pressure for long hose lays, elevated terrain, and tandem setups. Compact, lightweight, and widely used on Type 7 brush trucks.

Models:

- 100045 – STR2-13V (Honda GX390 / 2-Stage)
- 100141 – STR2-14V (B&S14 / 2-Stage)
- 100047 – STR3-13V (Honda GX390 / 3-Stage)
- 100166 – STR4-13V (Honda GX390 / 4-Stage)

Shared components with BB-4®, high pressure in a small package, ideal for Type 7 vehicles.



NEW

STR4-13V HONDA ENGINES Honda GX390

Item no: 100166

The new STR4-13V vehicle-mount unit is powered by the reliable 11.7 HP HONDA GX390 engine and couples the innovative, lightweight, corrosion-resistant 4-stage pump end from the MARK-3® Watson Edition to deliver exceptional durability and operating-range performance in demanding environments.

Flow rate at specified pressure
Maximum pressure: 310 PSI (21.4 bar)
Free flow: 118 US gals/min (447 L/min)
Maximum head: 715' (218 m)

Flow		Pressure	
US GPM	L/min	PSI	Bar
111	420	@ 100	6.9
92	347	@ 150	10.3
49.4	192	@ 250	17.2



STR2-13V HONDA ENGINES Honda GX390



Item no: 100045

The STR2-13V configuration is powered by a Honda 11.7 HP engine and vertical-drive unit in a vehicle mount configuration with a base mount and 8-pin FastWire connections.

Flow rate at specified pressure
Maximum pressure: 230 PSI (15.9 bar)
Free flow: 105 US gals/min (397 L/min)
Maximum head: 531' (162 m)

Flow		Pressure	
US GPM	L/min	PSI	Bar
97	367	@ 100	6.9
80	303	@ 150	10.3
58	220	@ 200	13.8



STR2-14V BRIGGS & STRATTON B&S Vanguard™

Item no: 100041

The STR2-14V is a compact, powerful vehicle-mounted pump driven by a 14 HP Briggs & Stratton engine and reliable vertical drive unit. It features the FastWire connection, ensuring seamless, reliable integration with WATERAX control panels.

Flow rate at specified pressure
Maximum pressure: 230 PSI (15.9 Bar)
Free flow: 105 US gals/min (397 L/min)
Maximum head: 531' (162 m)

Flow		Pressure	
US GPM	L/min	PSI	Bar
97	367	@ 100	6.9
80	303	@ 150	10.3
58	220	@ 250	17.2



STR3-13V HONDA ENGINES Honda GX390



Item no: 100047

The STR3-13V is powered by a 11.7 HP Honda engine and vertical-drive unit and configured for vehicle mounting with a base mount and 8-pin FastWire connections.

Flow rate at specified pressure
Maximum pressure: 345 PSI (23.8 bar)
Free flow: 102 US gals/min (386 L/min)
Maximum head: 797' (243 m)

Flow		Pressure	
US GPM	L/min	PSI	Bar
87	329	@ 100	6.9
75	284	@ 150	10.3
40	151	@ 250	17.2



DUAL CONTROL PANELS

The new **DCP200 Digital Control Panel** features a 2.8" colored LCD display. It enables start/stop, throttle control, continuous monitoring and protection of your pump. A remote DCP200R can be seamlessly added to support dual control panel applications like pump-and-roll operations.

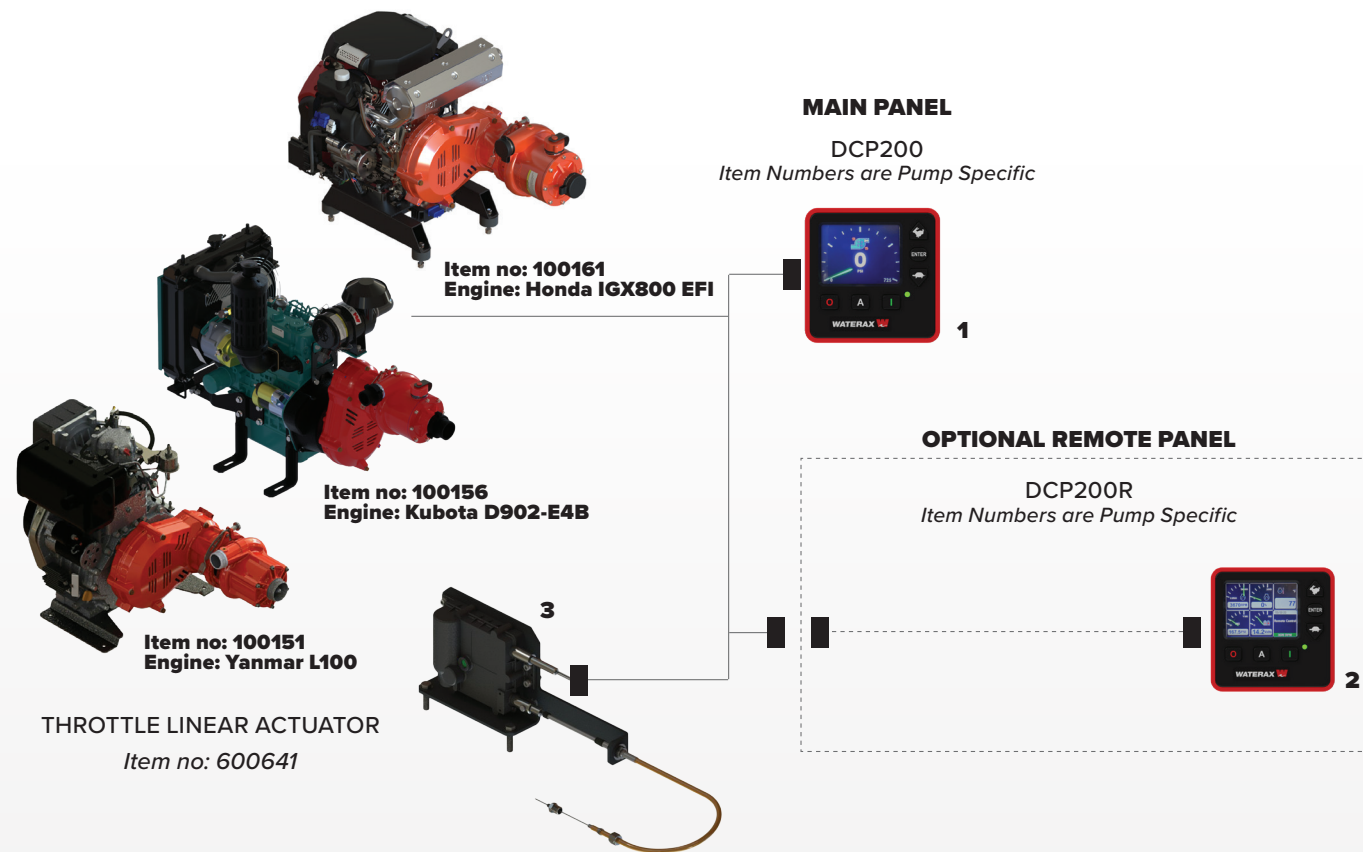

ID	ITEM NO	DESCRIPTION
1	600646	DIGITAL CONTROL PANEL - DCP200 MAIN D902
2	600647	DIGITAL CONTROL PANEL - DCP200R REMOTE D902
1	600648	DIGITAL CONTROL PANEL - DCP200 MAIN IGX800
2	600649	DIGITAL CONTROL PANEL - DCP200R REMOTE IGX800
1	600639	DIGITAL CONTROL PANEL - DCP200 MAIN DY10
2	600645	DIGITAL CONTROL PANEL - DCP200R REMOTE DY10
3	600641	THROTTLE LINEAR ACTUATOR FOR DCP

STRIKER™ SERIES - DIESEL

Compact Diesel High-Pressure Pump for OEM Applications

Combines the STRIKER™ platform with a Yanmar L100 diesel engine for fleets requiring diesel uniformity in small brush trucks or UTV firefighting modules.

Model:
100151 – STR4-DY10H (Yanmar L100 / 4-Stage)

Diesel solution for lightweight apparatus where gasoline is not preferred.

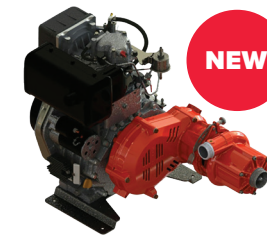

STR4-DY10H YANMAR L100

Item no: 100151

The **STR4-DY10H** combines a reliable YANMAR L100 diesel engine, producing 9.3 HP, and couples the innovative, lightweight, corrosion-resistant 4-stage pump end from the MARK-3® Watson Edition to deliver exceptional durability and operating-range performance in demanding environments.

The pump is fully compatible with the DCP, supporting both single and dual control panel configurations.

The engine speed can be controlled via the DCP through the use of a linear throttle actuator.

Compatible with DCP



Flow rate at specified pressure
Maximum pressure: **310 PSI** (21.4 bar)
Free flow: **112 US gals/min** (424 L/min)
Maximum head: **716'** (218 m)

Flow		Pressure		
US GPM	L/min	PSI	Bar	
85	322	@	100	6.9
65	246	@	150	10.3
28	106	@	250	17.2

BB-4® / B2X™ SERIES - DIESEL

Diesel-Powered High-Pressure and Mid-Range Solutions

Designed for departments requiring diesel standardization, these pumps pair WATERAX performance with diesel engines. Perfect for Type 4–6 apparatus, WUI support, and municipal wildland response.

Models:
100155 – BB-4-D902H (High-Pressure / 4-Stage)
100156 – BB-4-D902V (High-Pressure / 4-Stage)
100157 – B2X-D902H (Mid-Range / 2-Stage)
100158 – B2X-D902V (Mid-Range / 2-Stage)

Diesel engine compliance, long service life, ideal for municipal + wildland hybrid apparatus.

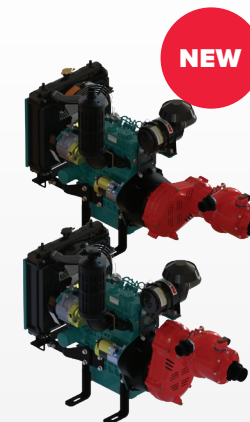

BB-4-D902H / BB-4-D902V Kubota D902-E4B

Item no: 100155 / 100156

* Available with both vertical or horizontal drive.

The new **BB-4-D902** is powered by the 24.8 HP Kubota D902 Diesel engine, configurable in both vertical and horizontal positions. It is fully compatible with the DCP, supporting both single and dual control panel configurations. The engine speed can be controlled via the DCP through the use of a linear throttle actuator.

Flow rate at specified pressure
Maximum pressure: **395 PSI** (27.2 bar)
Free flow: **106 US gals/min** (401 L/min)
Maximum head: **911'** (278 m)



Compatible with DCP

Flow		Pressure		
US GPM	L/min	PSI	Bar	
106	401	@	150	10.3
103	390	@	250	17.2
65	246	@	350	24.1



B2X-D902H / B2X-D902V Kubota D902-E4B

Item no: 100157 / 100158

* Available with both vertical or horizontal drive.

The new **B2X-D902** is powered by the 24.8 HP Kubota D902 Diesel engine, configurable in both vertical and horizontal position. It is fully compatible with the DCP, supporting both single and dual control panel configurations. The engine speed can be controlled via the DCP through the use of a linear throttle actuator.

Flow rate at specified pressure
Maximum pressure: **180 PSI** (12.4 Bar)
Free flow: **310 US gals/min** (1173 lpm)
Maximum head: **415'** (127 m)



Compatible with DCP

Flow		Pressure		
US GPM	L/min	PSI	Bar	
274	1037	@	50	3.4
220	833	@	100	6.9
112	424	@	150	10.3

VERSAX® SERIES



Versatile Twin-Impeller Pump for Fire & Utility Applications

The **VERSAX®** is a rugged, economical self-priming pump with excellent water-transfer and moderate firefighting capability. Used for tank-filling, irrigation, and light-duty brush trucks.

Models:
100093 – VS2-6V (Honda GX200/ 2-Stage)
100078 – VS2-9EV (Honda GX270 / 2-Stage)

Highly versatile for OEMs building multipurpose wildland support vehicles and lightweight support units.



VS2-6V Honda GX200

Item no: **100093**

The **VS2-6V** is powered by a 6 HP Honda engine configured for vehicle mounting.

Flow rate at specified pressure
Maximum pressure: **120 PSI** (8.3 bar)
Free flow: **105 US gals/min** (397 L/min)
Maximum head: **277'** (84 m)

Flow		Pressure	
US GPM	L/min	PSI	Bar
83	314	@ 50	3.4
63	238	@ 75	5.2
38	144	@ 100	6.9



VS2-9EV Honda GX270

Item no: **100078**

The **VS2-9EV** is powered by a 9 HP Honda engine configured for vehicle mounting, electric start and battery.

Flow rate at specified pressure
Maximum pressure: **150 PSI** (10.3 bar)
Free flow: **105 US gals/min** (397 L/min)
Maximum head: **347'** (106 m)

Flow		Pressure	
US GPM	L/min	PSI	Bar
92	348	@ 50	3.4
80	303	@ 75	5.2
64	242	@ 100	6.9



ACCESSORIES

DIGITAL CONTROL PANELS (DCP)



600639 - DCP200 MAIN DY10
600646 - DCP200 MAIN D902
600648 - DCP200 IGX800 EFI

DCP REMOTE WITH CONNECTOR KIT



600645 - DCP200R REMOTE DY10
600647 - DCP200R REMOTE D902
600649 - DCP200R REMOTE IGX800 EFI



600641
THROTTLE LINEAR ACTUATOR FOR DCP

CONTROLS



250234
MCP MINI CTRL PNL
W/FW CONN



250273
PMSCP-LPP CONTROL PANEL
W/ LOW PRESS PROTECTION



250290
ECP ENCLOSED
CONTROL PANEL



250233 - WCP WATERAX CONTROL PANEL
250229 - WCP-W WATERAX CONTROL PANEL WATER

PRIMERS



250238
EPRIMERKIT ELECT PRMR
W/CBL, SWITCH, PLM



250237
GZPRIMERKIT GZ HND
PRMR W/PLUMBING

ELECTRIC KIT



250249
BATKIT-20P BATTERY KIT
12V 20AH, PORTABLE

FASTWIRE CABLES



600543
FWX-3 3' EXTENSION
FASTWIRE CABLE

ENGINE ACCESSORIES FOR KUBOTA D902



701421
SPARK ARRESTOR SUPER
TRAPP, ADAPTOR 1-1/2" INLET



701419
AUXILIARY FUEL PUMP
FOR KUBOTA D902



701466
FUEL CHECK VALVE
FOR KUBOTA D902



701420
ANTI-VIBRATION
MOUNTS FOR DIESEL

COUPLINGS



300771
ADP-A-FM15SV 1-1/2
NPSH F TO VICTAULIC



300770
ADP-A-FM15SV 2 NPSH F
TO VICTAULIC

FOAM EDUCTOR



301959
SCO-4171KIT FOAM EDUCTOR
KIT W/HOSE AND TEES

*already included on Diesel models



PARTNER WITH WATERAX

OEM sales engineering, tech sheets, CAD files, demos, and integration support available upon request.



WATERAX INC.
6635 Henri-Bourassa W.
Montréal, QC H4R 1E1
T 514-637-1818

WATERAX CORP.
3701 Innovation Way,
Valparaiso, IN 46383
T 360-574-1818

FOLLOW US



info@waterax.com
www.waterax.com

TF 1-855-616-1818