



MINI-STRIKER®

DATA SHEET

LIGHTWEIGHT PRESSURE FIRE PUMP

The *WATERAX* MINI-STRIKER® pump pairs a reliable single stage pump end with the Honda 4-stroke 2.5 HP engine to achieve pressures of up to 85 PSI (5.9 BAR) and offer volume supply of up to 80 GPM (303 L/Min). Extremely portable and lightweight, this mini powerhouse performs well when used by itself or in tandem with other pumps, and is a very popular choice for entry level slip-on applications. It is also particularly suited to some of the latest fire control techniques where small, lightweight equipment is a requirement. The widely-available Honda 4-stroke 2.5 HP engine makes for ease of operation and engine parts sourcing.

Emissions compliant; engine is CARB and EPA certified

Applications

- Attack line firefighting
- Sprinkler operations
- Tandem pumping over long distances
- Entry level slip-on units

Features and Benefits

- Lightweight aluminum alloy pump components
- Portable and compact
- Comprehensive user and service manuals

SPECIFICATIONS

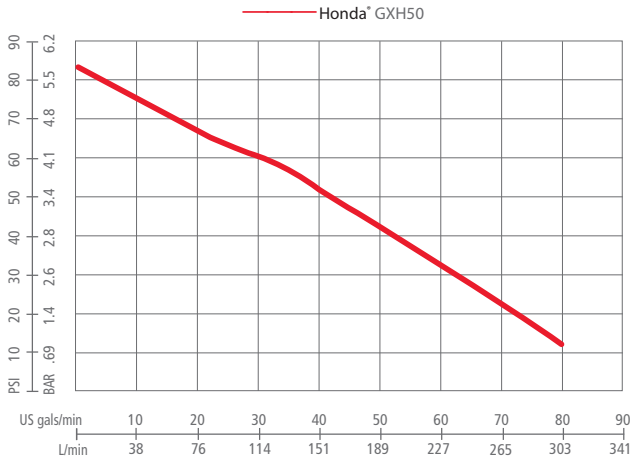

Flow rate at specified pressure

Maximum Pressure: 85 PSI (5.9 bar)

Free flow: 80 US gals/min (303 L/min)

Maximum Head: 196' (60 m)

Flow Rate		Pressure		
US GPM	(LPM)	@	PSI	(BAR)
68	(257)	@	25	(1.7)
42	(159)	@	50	(3.4)
12	(45)	@	75	(5.2)

Engine: Honda® GXH50

Engine Specifications

Model & Type	Honda, GXH50 Series 4-stroke, horizontal shaft, single cylinder, OHV
Net Power Output	2.1 HP (1.6 kW) @ 7000 RPM
Net Torque	2.0 lb-ft (2.7 Nm) @ 4500 RPM
Bore & Stroke	1.65 x 1.42 inches (41.8 x 36 mm)
Displacement	3.01 cubic inches (49.4 cc)
Starting System	Recoil
Ignition	Transistorized Magneto
Governor	Centrifugal Mechanical
Air Cleaner	Semi-dry
Cooling	Air Cooled
Lubrication	Forced Splash
Oil Capacity	0.26 quarts (0.25 liters)
Carburetor	Float Type
Emissions	Meets current CARB, EPA, and CE requirements.
Exhaust	US Forestry Service Approved Spark Arrestor
Fuel Type	Gasoline [unleaded, 86 minimum octane or higher, 10% maximum ethanol]
Fuel Tank:	Integral 0.81 quarts (0.77 liters)
Fuel Consumption	0.24 US gal/hr (0.91 L/hr)

Unit Base Specifications

MSTR-P:
Black flat polyethylene base with four rubber pads. Unit also provided with a single black composite carry handle mounted on the top for transporting.

Pump Specifications

Type	Single Stage Centrifugal; Direct Drive
Description	Foam Compatible
Maximum Allowable Pressure	200 PSI (13.8 bar)
Maximum Pressure	85 PSI (5.9 bar)
Maximum Flow	80 GPM (303 lpm)
Intake	1-1/2" Male NPSH Thread. Protected by Rubber Cap with Retainer (MSTR-P only)
Discharge	1-1/2" Male NPSH Thread. Protected by Rubber Cap with Retainer (MSTR-P only)
Body & Diffusers	Anodized corrosive resistant aluminum
Impellers	Anodized corrosive resistant aluminum
Pump Shaft	Stainless Steel
Pump Seal	Heat Resistant Rotary Mechanical Seal – Maintenance Free
Color	Red

Controls

Engine choke, shut-off, throttle, and fuel valve control levers with low oil pressure shutdown.

MSTR-V:

Four industrial isolators mounted directly to the engine base with M6 x 1.0 female thread.

All features are not available on every model. Please refer to the product selection matrix to select the proper model.



WE MOVE WATER

TECHNICAL DRAWINGS

MSTR-P Length 12-5/8" (32 cm) Width 10-3/4" (27.3 cm) Height 15-1/2" (39.3 cm) Weight 20 lbs (9 kg)

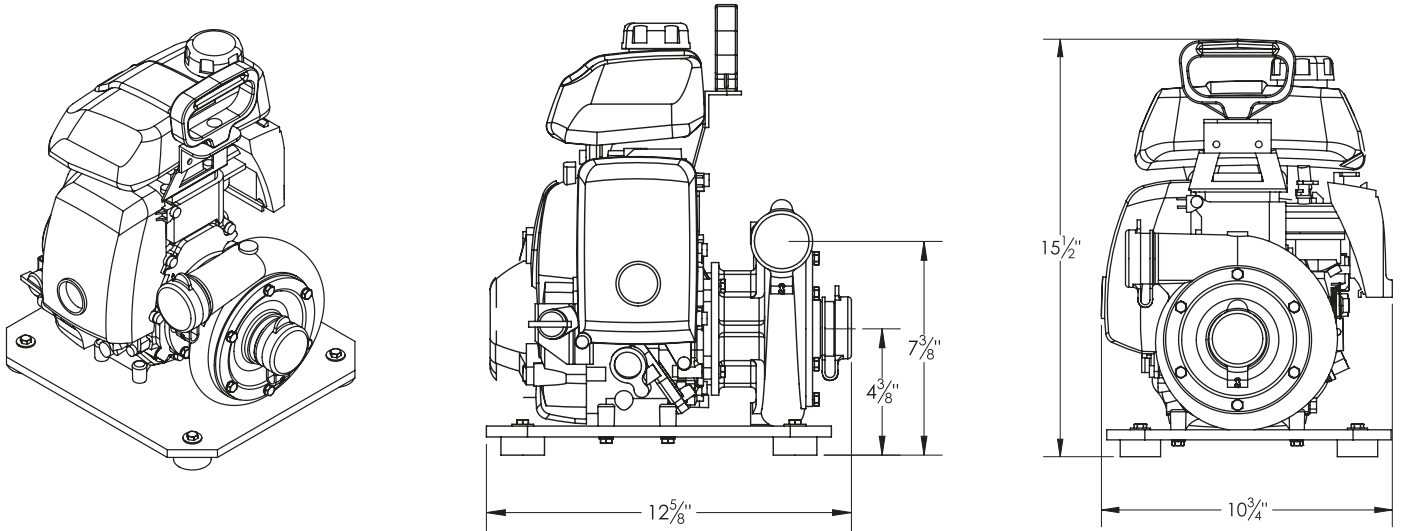

MSTR-V Length 12" (30.4 cm) Width 10-3/4" (27.3 cm) Height 14-7/8" (37.7 cm) Weight 19 lbs (8.6 kg)

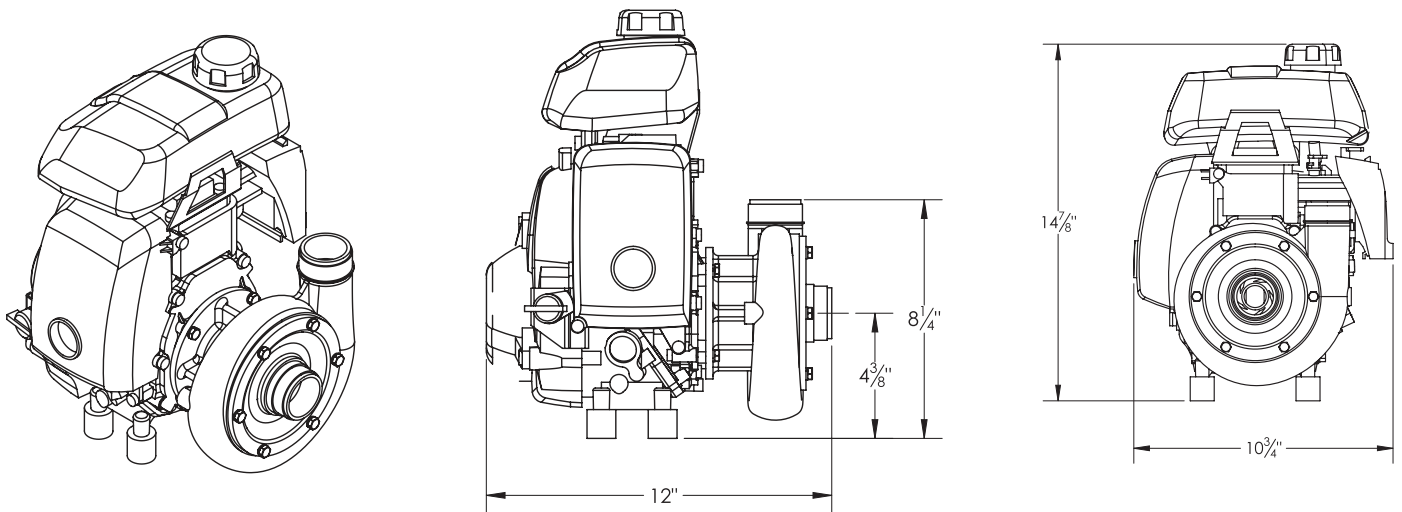

WATERAX

All information contained in this document including drawings is proprietary to *WATERAX* and may not be copied, reproduced or used in whole or in part without our prior written permission. The information in this document is subject to change without notice. Model displayed with multiple options. Weight and dimensions are approximated and may vary depending on options.

WATERAX INC.

6635 Henri-Bourassa W.
Montreal, QC H4R 1E1

T 514 637-1818

F 514 637-3985

TF 1 855 616 616-1818

info@waterax.com

waterax.com

To help you stay **#ReadyForWildfires**, we've made a few changes, placing 100% of our focus on manufacturing our core products, portable fire pumps.

To do so, we've established a network of trusted supply and distribution partners that can help us provide *WATERAX* pumps quickly in addition to water-handling equipment and accessories.

For immediate assistance when it comes to pumps and water-handling accessories, please contact your local dealer.

For genuine spare parts, visit our online store.

MINI-STRIKER® is a trademark of Waterax.



**WE MOVE
WATER**