

# WATERAX

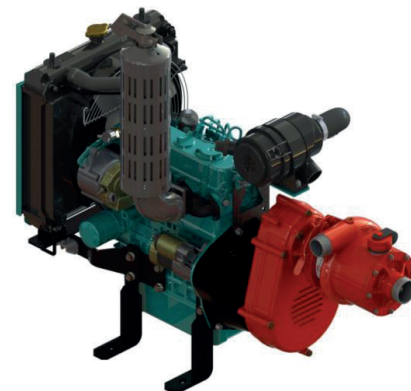

## BB-4<sup>®</sup>-D902

### QUICK GUIDE

This Quick Guide shows the basic operation of the *WATERAX* BB-4-D902 4-stage high pressure pump.

- The *WATERAX* BB-4-D902 pairs a *WATERAX* 4-stage pump end with a Kubota 902 diesel-powered engine. For instructions regarding the engine, as well as for oil and fuel recommendations, please refer to the engine manufacturer's manual.
- For detailed instructions on using and troubleshooting your pump, as well as full service and maintenance instructions, refer to our website to download the BB-4 Owner's Manual.
- For full specifications and performance curves, see the BB-4-D902 Data Sheet.



## Warnings and Safety Precautions

This warning label appears on all *WATERAX* pumps to identify safety hazards as follows:



### READ YOUR ENGINE MANUAL!

Before proceeding further, locate and read the engine manufacturer's manual. It contains very important safety information that **MUST** be read, understood and followed to safeguard you and your equipment from harm, as well as for the proper use and care of your engine. Use only fuel and oil type recommended in the engine manufacturer's manual. Always check oil level in crankcase and radiator coolant level before use.



### WEAR EAR AND EYE PROTECTION.

Always wear eye and ear protection when operating the pump unit. Sound level of the unit: 92 dB(A).



### GENERAL WARNINGS:

- Do not operate if mentally or physically fatigued.
- Inspect hoses and piping to avoid burst injuries.
- No modifications and/or alterations may be made to the pump. Any such modifications void the pump warranty and can endanger pump operators.
- Do not operate the pump above the maximum rated pressure. Use only pipe, hose, and fittings rated at or above the maximum pressure rating of the pump or system design.
- Slowly close valves. Use slow close valves wherever possible to safeguard operators and prevent damage from water hammer.
- Dry weight of the unit: 280 lbs.



## QUICK GUIDE



### READ THE PUMP OWNER'S MANUAL!

The improper use of this pump could result in serious injuries as well as damage to the unit. Read the *BB-4 Owner's Manual* before using your BB-4 pump unit and follow the safety instructions in this Quick Guide.



### NEVER RUN THE ENGINE IN A CLOSED OR CONFINED AREA.

Exhaust gas contains carbon monoxide which is poisonous to humans. Avoid inhalation of exhaust gas.



### REFUEL ENGINE WITH CARE.

Diesel is flammable. Refuel in a well-ventilated area, with the engine stopped.



### NEVER TOUCH ANY EXHAUST OR COOLING SYSTEM PARTS WHILE ENGINE IS RUNNING.

Always allow enough time, after stopping the unit, for proper cooling of these parts and surrounding areas.

### EQUIPMENT DAMAGE PREVENTION:

- Flush the pump with fresh water if the pump has been used to pump salty, brackish, high mineral content water, water containing debris, or foam injected water. Check that debris is cleared before using the pump again.
- Always draft water using a suction hose strainer.

## Parts Identification

- A. Priming cap
- B. Pump intake (suction)
- C. Pump drain port (not shown)
- D. Pump discharge
- E. Quick release pump clamp
- F. Radiator coolant cap
- G. Coolant overflow (not shown)
- H. Muffler
- I. Throttle (not shown)
- J. Oil fill plug
- K. Oil dipstick (not shown)
- L. Fuel valve (not shown)
- M. PMSCP-DIESEL control panel\*

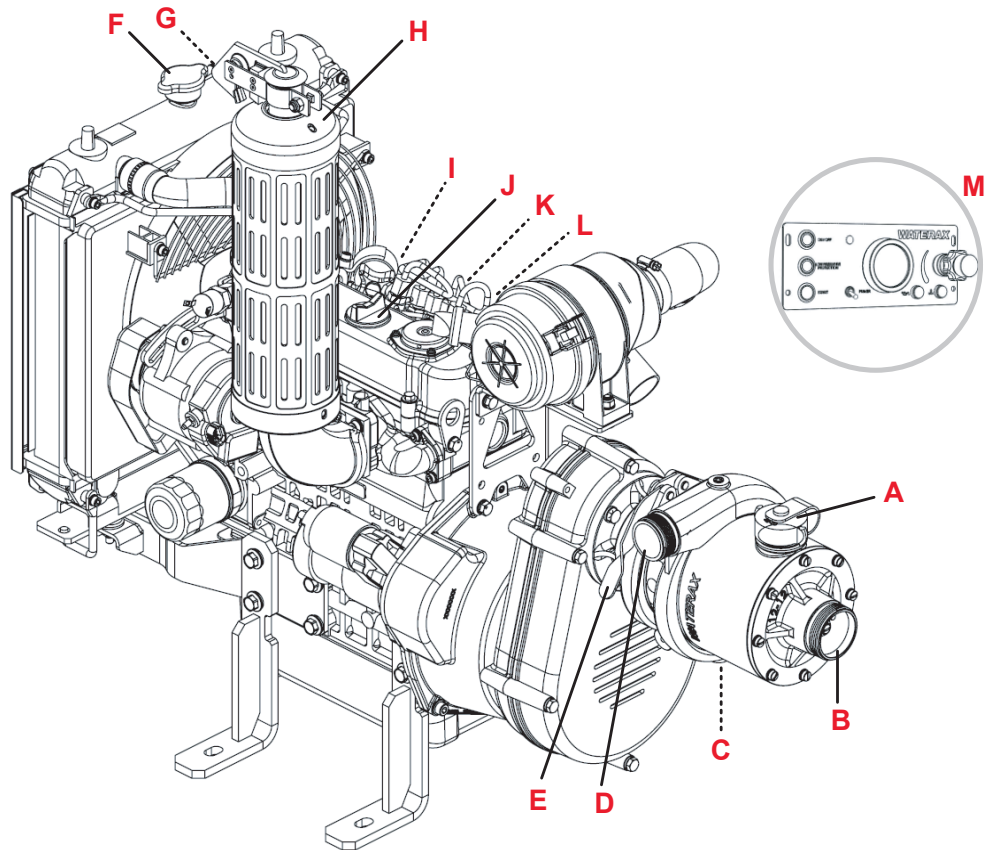

\* Please refer to your control panel user instructions for installation and wiring procedures



## QUICK GUIDE

### To operate the BB-4-D902 unit:

1. **Supply recommended diesel fuel grade to engine.** Do not mix gasoline or alcohol with diesel fuel. If using a fuel line, connect the line according to the engine manufacturer's instructions.

2. **Connect the suction hose,** using a universal hose coupling wrench to tighten coupling firmly:

**Drafting Mode:** Connect footvalve strainer to male end of suction hose, then fill suction hose with water and connect to pump intake.

**Flooded Suction Mode:** Connect female end of suction hose to pump intake and connect male end to hydrant or other supply.

- Slowly open the pump inlet valves allowing the water into the pump body.
  - Slowly open the discharge valves and priming valves to allow for entrapped air in the piping to escape.
  - Once all the air has escaped, slowly close any opened discharge valves so that the unit may be started.
3. **Connect discharge hose, nozzles, etc., to pump,** and tighten firmly with coupling wrench.

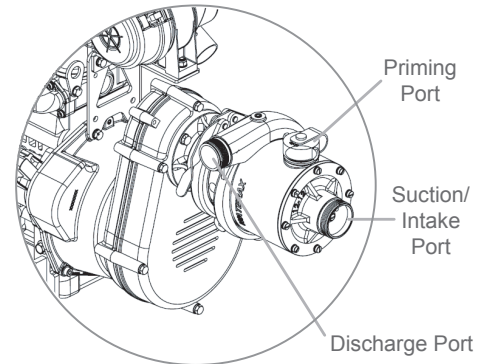

- ! **DO NOT** allow footvalve strainer to rest on bottom of lake or riverbed. Check strainer frequently to make sure that it is not clogged with moss, leaves, etc.
- ! **DO NOT** lift strainer from water while the pump is operating. Use a rope or other means to keep strainer at proper height, approximately 1 foot (30 cm) below water surface. If strainer is too close to the water surface, it will draw air and pump may lose prime.

4. **Activate the control panel.** If you are using the Panel Mount Standard Control Panel (PMSCP-DIESEL), push the control panel's ON/OFF button. A green ring on the button will light up indicating that the panel is powered.

5. **Prime the pump.** Check that all drains, discharge valves, or any auxiliary valves are closed before priming the pump. Open the priming ball valve (located between the pump and the primer).

**Manual Priming:** Open the priming cap and fill pump with water manually. Firmly tighten priming cap. Pump can also be primed by "jerk" the suction hose until water flows from the pump's discharge port.

**Guzzler Priming:** If equipped with a Guzzler primer, follow the hand pump manufacturer's operation instructions. Pump until water is drawn into the pump.

**Electric Priming:** If your pump is equipped with a *WATERAX* electric primer, move the PRIMER toggle switch on your control panel to the up position and hold it in place to allow water to enter the pump. The electric primer is intended to be used only a short duration (about 20 seconds). If pump fails to prime, see the *BB-4 Owner's Manual* for troubleshooting tips.

**Close the priming ball valve after priming.** Failure to close the priming valve could cause the pump to lose prime or water to be pumped through the priming system.

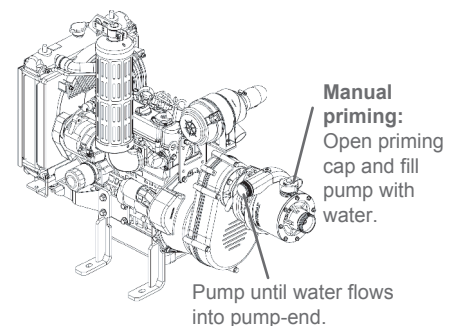

## QUICK GUIDE

### 6. Start the engine.

- Warm up: The electric starter's glow plugs require a 10-second warm-up period which begins as soon as you push the ON/OFF button on the control panel. During the warm-up period, the START button is deactivated and the engine cannot be started. As soon as the warm-up period is over, the low oil pressure (  ) light will turn on, indicating that the engine is ready to start.
- Make sure all discharge valves are closed.
- Push and hold the START button on the control panel until the engine engages.
- Turn the Vernier throttle counter-clockwise to increase engine speed past the idle position. Pressure should build up in the system.

### 7. Discharge water.

Once the pump is primed, and with the engine running, you can begin to discharge water.

- Slowly open the discharge valve. If pressure does not build in the discharge hose, the pump has not been fully primed. The valve should be closed and the pump primed again.
- Adjust the pump performance by throttling the engine up or down, or opening or closing discharge valves at various positions, or any combination of the two.
- Press the LOW PRESSURE PROTECTION button to activate the protection. If pressure drops below 7 psi (loss of prime condition), the engine will automatically shut down to protect the pump.

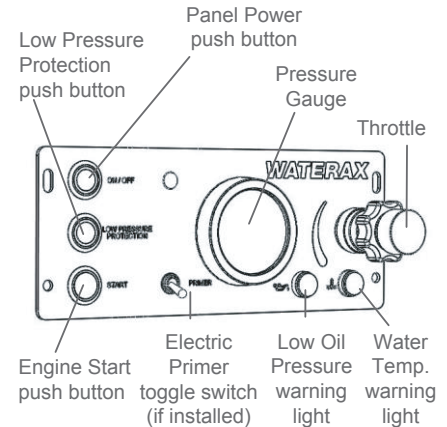

PMSCP-DIESEL Control Panel

**! DO NOT** leave the pump running with all the discharge valves closed for more than one minute, or else the pump may overheat and become damaged. To avoid this, a re-circulation line (if provided) should be opened or a discharge line left slightly open to allow fresh water to continue to enter the pump.

### To shut down and store the BB-4-D902 unit:

1. **Shut down the pump.**
  - a. Gradually reduce the engine speed.
  - b. Whenever the unit has been run at full throttle for most of the operation, allow the valves to remain slightly open and run the engine at idle for approximately 5 minutes before shutting down the unit.
  - c. Turn off engine.
  - d. Close off the hydrant/supply to the pump.
  - e. Open all valves to relieve any pressure left in the system.
2. **Check and store the pump.**
  - a. If the pump was last run with foam or water that is salty, brackish or high in mineral content, flush the pump with fresh water for a minimum of 2 minutes or until water is clear.
  - b. After the unit has cooled down, check all fluid levels and add as needed.
  - c. Completely drain the pump of all water.
  - d. Break down and store all equipment as outlined by the apparatus or department procedures.
  - e. Visually inspect the pump end. Clean any dirt or debris from the pump unit. If necessary, a mild soap and water solution can be used. Note and report any performance irregularities or any abnormal mechanical sounds.
  - f. Close all valves and plug all openings.
  - g. Follow any other product, component, apparatus, and departmental procedures and/or guidelines before placing the unit in storage. Make sure all necessary tools, spares, and accessories are with the pump.

### To operate the BB-4-D902 unit in cold weather:

The pump can be run in below freezing temperatures if certain precautions are taken to avoid the formation of ice in the pump.

After priming the pump, the unit should be run at low speed for a short period of time to allow all components to warm up before continuing with the remaining operating procedures.

Unless wrapped in a heater, drain the pump of all water if it is stopped for any length of time. The engine/drive unit should be turned over a few revolutions to make sure all water has been removed from the pump. Drain the pump priming line if a primer has been used.

After use, drain the pump, manifolds, and lines of all water. You can also pour some RV antifreeze into the pump and circulate it through the pump and plumbing system.

### Warranty, Service and Support

Product and service documentation such as tech notes, data sheets, manuals and information on the limited warranty provided on products manufactured by WATERAX can be found on our Web site at: [www.waterax.com](http://www.waterax.com)



# **WATERAX**

All information contained in this document including drawings is proprietary to *WATERAX* and may not be copied, reproduced or used in whole or in part without our prior written permission. The information in this document is subject to change without notice. Model displayed with multiple options. Weight and dimensions are approximated and may vary depending on options.

**WATERAX INC.**

6635 Henri-Bourassa W.  
Montreal, QC H4R 1E1

T 514 637-1818

F 514 637-3985

TF 1 855 616 616-1818

[info@waterax.com](mailto:info@waterax.com)

**waterax.com**

To help you stay **#ReadyForWildfires**, we've made a few changes, placing 100% of our focus on manufacturing our core products, portable fire pumps.

To do so, we've established a network of trusted supply and distribution partners that can help us provide *WATERAX* pumps quickly in addition to water-handling equipment and accessories.

For immediate assistance when it comes to pumps and water-handling accessories, please contact your local dealer.

For genuine spare parts, visit our online store.

BB-4®-D902 is a trademark of Waterax.



**WE MOVE  
WATER**