

# **WATERAX**

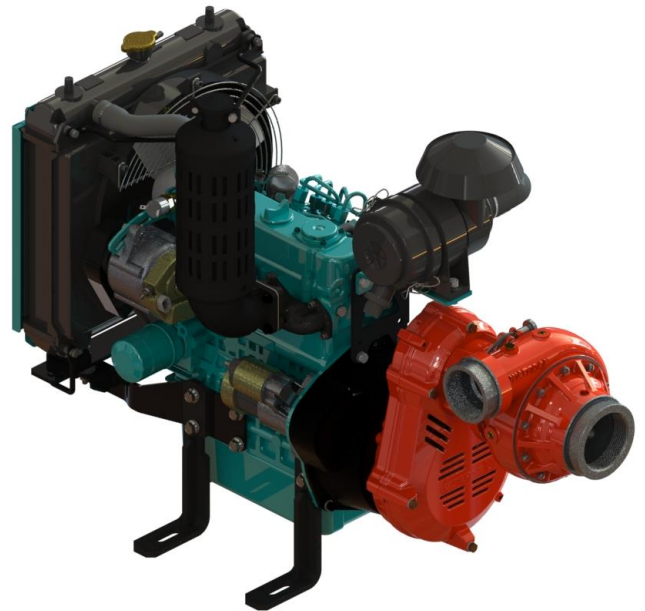

## **B2X™**

# **Owner's Manual**

Publication Date: 07/2025  
Publication Number: 701224, Rev.7



**WE MOVE  
WATER**

This document provides information proprietary to WATERAX Inc. and cannot be used or disclosed without WATERAX's written authorization.

WATERAX Inc. reserves the right to make changes without notice in its products or components as research and development or marketing conditions warrant. Changes affecting the operation of any component in this manual will be reflected in a subsequent revision. WATERAX Inc. assumes no responsibility for any omissions or errors that may appear in this document or for any damages that may result from the use of information contained herein.

The following are trademarks or brand names of WATERAX Inc.: WATERAX, '*WE MOVE WATER*'.

All other trademarks used in this manual are the exclusive property of their owner.

**B2X™ Owner's Manual**

Publication No.: 701224, Rev. 7

Publication Date: 07/2025

First Edition: February 2015

**Published by:**

WATERAX Inc.

6635 Henri-Bourassa W.

Montreal, Quebec H4R 1E1

CANADA

Copyright © 2025 WATERAX Inc.

All rights reserved

Printed in Canada



# Contents

- Important Safety Instructions ..... 5**
  - Personal Safety Advisory ..... 5
  - Warnings..... 5
- Preventing Damage to Equipment ..... 6**
- Introduction ..... 7**
  - About this Manual ..... 7
  - Abbreviations and Terms..... 7
  - About the B2X Series ..... 8
  - Parts Identification ..... 9
- Installation ..... 10**
  - Plumbing..... 10
  - Pump End Mounting ..... 10
  - Fastening to Truck/Apparatus ..... 10
  - Installing a Control Panel..... 11
  - Using a Battery for Electric Starters and Control Panels ..... 11
  - Supplying Fuel to the Engine..... 11
- Operating B2X Series Pumps ..... 12**
  - Pre-Operation Checklist ..... 12
  - Flooded Suction..... 12
  - Drafting ..... 13
  - Priming the Pump ..... 14
  - Startup and Discharge ..... 15
  - Shutdown..... 16
  - Cold Weather Operation..... 17
  - Basic Care and Storage ..... 17
  - Troubleshooting..... 18
- Service..... 20**
  - Drive Assembly Parts Breakdown ..... 20
  - Installing the Drive Assembly ..... 21
  - Removal of Pulley Assembly ..... 25
  - Removing or Attaching the Pump End ..... 25
  - B2X Portable Frame Assembly ..... 26
  - B2X-23 Low Tone Mufflers ..... 26
  - B2X-18 Low Tone Mufflers ..... 26
  - Guzzler Primer..... 27
  - Check Valve Assembly..... 27
  - B2X Priming System..... 28
  - EPA/CARB 1 US Gal Fuel Tank Assembly ..... 28
  - Work Light Assembly..... 29
  - Engine Mount Control Panel ..... 29
  - Electric Primer Assembly..... 30
  - Exhaust Primer Assembly ..... 30
  - Battery Kit..... 31
  - Vehicle Mount Frame Assembly..... 31
  - Exhaust Primer Assembly for Vehicle Mount ..... 32
  - B2X Pump End Parts Breakdown ..... 33
  - Disassembly Procedure for B2X Pump End..... 34
  - Assembly Procedure for B2X Pump End ..... 34



Pump Clamp ..... 36  
Assembly of B2X-D902 Stub Shaft and Engine Housing ..... 36  
Assembly of B2X-D902 Air Filter ..... 37  
Assembly of B2X-D902 Engine High Temp Sending Unit ..... 38  
Assembly of B2X-D902 Low Oil Pressure Sending Unit ..... 38  
B2X Wiring ..... 39  
FastWire Wiring Diagrams ..... 41  
**Pump End Technical Data ..... 43**  
**Notes ..... 44**  
**Warranty ..... 47**



# IMPORTANT SAFETY INSTRUCTIONS

## Personal Safety Advisory



### READ THIS MANUAL BEFORE OPERATING YOUR PUMP!

The improper use of the WATERAX pump could result in serious injuries as well as damage to the pump. This manual contains very important safety information that **MUST** be read, understood, and followed to safeguard you and your equipment from harm, as well as specific information on the proper use and care of your engine. Any operator should familiarize himself with the apparatus and its capabilities before trying to operate the equipment in an emergency situation. Please read this entire manual before using your WATERAX pump and follow all Personal Safety Advisories. **This pump must only be operated by trained personnel.**



## Warnings



- Do not operate if mentally or physically fatigued.
- Always inspect hoses and piping to avoid burst injuries.
- No modification and/or alteration may be made to the pump. Any such modification not only voids the pump warranty but can endanger pump operators.
- Do not operate the pump higher than the maximum rated pressure. Always run the unit at the lowest pressure required for the application to enhance operator and equipment safety.
- Use only pipe, hose, and fittings that are rated at or above the maximum pressure rating of the pump, or according to what maximum pressure the system was designed for, whichever is lower.
- Maximum Pressure Rating: 400 PSI (28 bar)
- Maximum Allowable Pump Intake Pressure: 150 PSI (10.3 bar)
- Slowly close valves and use slow close valves wherever possible to prevent danger to other line operators and to prevent water hammer which could damage the pump and its piping components.



- **Always wear eye and ear protection** when operating the pump unit.
- Ensure sufficient lighting (5 lx min.) during operation.



- **Never run the engine in a closed or confined area.** Exhaust gas contains carbon monoxide which is poisonous. Avoid inhalation of exhaust gas.



- **Refuel engine with care.** Gasoline is extremely flammable, and gasoline vapor can explode. Refuel in a well-ventilated area, with the engine stopped. Use only fuel and oil type as recommended.



- **Be alert and never touch any part of the engine exhaust system while the engine is running.** Always allow enough time, after stopping the unit, for proper cooling of these parts and surrounding area. Wear protective gloves.

- Leaving the pump running with all the discharge valves closed is called deadheading the pump (shut-off). **The pump should not be left in this mode for more than a minute.** Leaving in this condition for any length of time will cause the pump to overheat and can damage the pump. Additionally, the pump end and the water inside it can become extremely hot and cause severe burns. **Be careful when opening the discharge valve and avoid touching the pump end.** To avoid overheating the pump, a re-circulation line

(if provided) should be opened, or a discharge line left slightly open to allow fresh water to continue to enter the pump.

- Relieve all system pressure before doing any service work on the pump.

## PREVENTING DAMAGE TO EQUIPMENT

The following recommendations will help avoid damage to your equipment:

- Always use the proper fuel.
- Do not run the engine at full speed until thoroughly warmed up.
- Do not lift strainer out of the water while pump is operating.
- Do not run engine with pump disconnected.
- Do not run the pump when dry.
- Always draft water using a foot valve suction hose strainer.
- Position the foot valve to avoid drawing any type of sediments into the pump. Sand, silt, and mud are abrasive: do not allow the foot valve strainer to rest on bottom of lake or riverbed.
- Position the foot valve to avoid drawing air into the pump. Keep foot valve approximately 1 foot (30 cm) below the water surface. Securely attach in the presence of waves.
- Check strainer frequently to make sure that it is not clogged with moss, leaves, etc.
- Flush the pump with fresh water if the pump has been used to pump salty, brackish, high mineral content water, water containing debris, or foam injected water. Check that debris is cleared before using pump again.
- Drain pump after final use.
- During freezing weather, drain the pump and lines of all water. You can also pour some plumbing antifreeze into the pump and circulate it through the pump and plumbing system.
- Pumps should not be operated without water for any extended period of time or without discharging water. Operating the pump in such a manner can overheat the pump causing damage to seals, or pump internals.
- It is recommended that all parts be replaced with genuine WATERAX parts.
- If applicable, always check for enough oil quantity in the engine crankcase before use (see engine manual for details on checking the oil level, as well as for the type of oil to use).
- If applicable, always check for enough coolant quantity in the engine radiator before use (see engine manual for details on checking the coolant level, as well as for the type of coolant to use).
- When mounting manifolds to the pump, the manifolds must be self-supporting and coupled to the pump by means of a flex coupling such as a Victaulic® coupling or flex hose.
- When hoisting the pump onto an apparatus, take care when using lifting hooks (if applicable) and avoid any contact with components adjacent to the fixation points.
- Never disconnect the battery (if applicable) while the engine is running, as this may damage the control panel's electrical components.



# INTRODUCTION

## About this Manual

This manual contains general operation, care and servicing procedures for the following WATERAX B2X mid-range 2-stage centrifugal pumps:

<b>Pump designation</b>	<b>Engine used</b>
B2X-18	Briggs & Stratton 18 HP gasoline engine
B2X-23	Briggs & Stratton 23 HP gasoline engine
B2X-21	Honda GX630 21 HP gasoline engine
B2X-D902	Kubota D902 25 HP diesel engine

These instructions cover most wildland and municipal pump applications. If the application the pump is being used for does not fall into these general guidelines, consult WATERAX Inc. for any additional safeguards, operating, or maintenance considerations that may be required.

For full service and maintenance instructions regarding the pump, please refer to the Service section. For maintenance instructions regarding the engine, as well as for oil and fuel recommendations, refer to the engine manufacturer's manual.

Please consult [www.waterax.com](http://www.waterax.com) for additional documentation related to this product such as the WATERAX product guide, parts catalog, technical notes, news, and other updates about WATERAX and its goods and services. Refer to "Tech-Notes" for the latest engineering changes and recommendations, which have been introduced since the publication of this manual.

## Abbreviations and Terms

The following terms and abbreviations are used in this manual:

---

<b>Cavitation</b>	Formation of air bubbles in a liquid inside a centrifugal pump, causing low pressure points and loss of pump capacity.
<b>Dead heading</b>	Also called shut-off. Leaving the pump running with all the discharge valves closed. The pump should not be left in this mode for more than a minute since the pump can overheat and become damaged. To avoid this, a re-circulation line (if provided) should be opened or a discharge line left slightly open to allow fresh water to continue to enter the pump.
<b>Drafting</b>	Process of using vacuum (suction) to take water from a stream or impoundment.
<b>NH</b>	National Hose. This is a type thread specified in NFPA 1963. Formerly known as NST (National Standard Thread).
<b>NPSH</b>	National Pipe Straight Hose. This is a type of thread that is slightly smaller in diameter than NH, with more threads per inch than the same nominal size of NH thread. NPSH is also called IPT (Iron Pipe Thread).
<b>NPT</b>	National Pipe Thread Taper. Used on threaded pipes and fittings.
<b>RPM</b>	Revolutions Per Minute.

---



## About the B2X Series

### Features

For full specifications and performance curves, see the Product Data Sheet. Applications of the **WATERAX B2X** series include:

- Slip-on units
- Attack line firefighting
- Long hose lay for remote watering during firefighting operations
- High elevation firefighting in mountainous areas
- Accuracy in flow trajectory when structure firefighting
- Tandem pumping over long distances
- Parallel pumping for higher volumes

Features and Benefits of the **WATERAX B2X** series include:

- Quick release clamp and swappable pump ends for minimal equipment downtime and inventory
- Sealed bearing to eliminate pump end greasing in the field
- Belt drive system for reliable, low maintenance performance
- Aluminum alloy pump components and anodized parts for lighter weight and greater resistance to corrosion
- Compatible with foam applications
- Blister resistant mechanical rotary seal
- Comprehensive manuals
- EPA Certified

### Configurations

The B2X series is used for a variety of wildland and municipal firefighting applications. Your model may be configured as a **portable**, standalone pump installed on a carry frame, or it may be purchased in the **vehicle-mount** configuration which includes a mounting frame or legs to fasten the pump onto a fire apparatus.



## Parts Identification

### B2X-18/23<sup>(1)</sup>

- A. Rewind starter (not shown)
- B. Throttle\*\* (not shown)
- C. Choke (not shown)
- D. Control panel\*† (option)
- E. Exhaust primer\*‡ (option)
- F. Guzzler primer\* (option)
- G. Priming port
- H. Starter key switch\*\* (not shown)
- I. Fuel valve\* (not shown)
- J. Fuel pump (not shown)
- K. Low-tone muffler
- L. Pump discharge
- M. Quick release pump clamp
- N. Pump drain ports (not shown)
- O. Pump intake (suction)

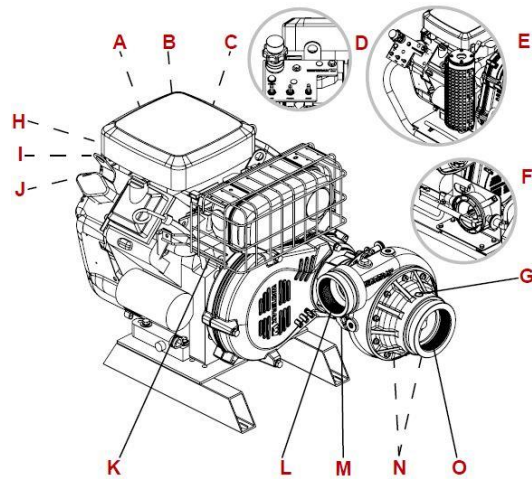

(1) B2X-18H vehicle-mount model shown.

\* Denotes optional components.

\*\* Items not available when Control Panel Option is selected.

† Engine mounted control panel shown. Other options are panel mount control panels and skid mount panels.

‡ Replaces low-tone muffler

### B2X-21

- A. Throttle
- B. Choke (not shown)
- C. Starter key switch (not shown)
- D. Muffler
- E. Pump discharge
- F. Quick release pump clamp
- G. Pump drain ports (not shown)
- H. Pump intake (suction)
- I. Priming port

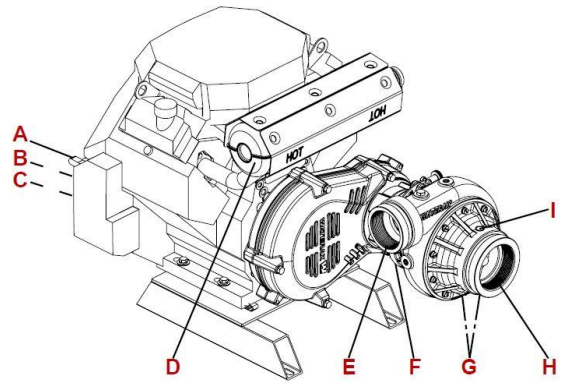

### B2X-D902

- A. Radiator coolant cap
- B. Coolant overflow (not shown)
- C. Muffler
- D. Throttle (not shown)
- E. Oil fill plug
- F. Oil dipstick (not shown)
- G. Fuel valve (not shown)
- H. PMSCP-DIESEL control panel\*
- I. Quick release pump clamp
- J. Priming port
- K. Pump discharge
- L. Pump drain ports (not shown)
- M. Pump intake (suction)

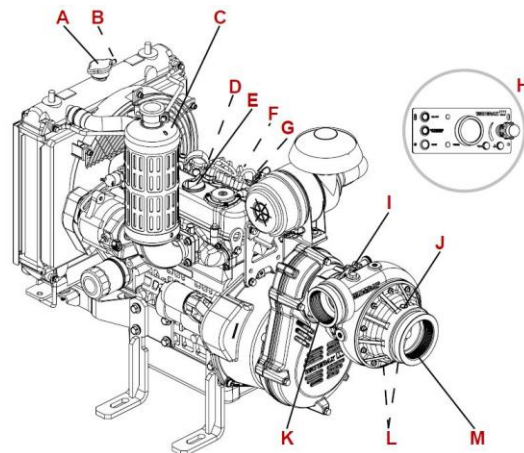

\* Please refer to your control panel user instructions for installation and wiring procedures

# INSTALLATION

Depending on your model and configuration ordered, you may require additional accessories from WATERAX or from third-party vendors, for example, control panels, batteries, and fuel lines. You will also require hoses and nozzles as well as other fire apparatus plumbing which can be purchased through your WATERAX representative. Follow the instructions and heed all warnings in any documentation that you receive with the accessories you purchase.

## Plumbing

When mounting manifolds to the pump, the manifolds must be self-supporting and coupled to the pump by means of a flex coupling such as a Victaulic® coupling or flex hose.

## Pump End Mounting

The pump end can be rotated to aid with the apparatus piping connections. The quick release pump clamp securely holds the pump end in the desired position. Always ensure that the water can be drained from the pump end to keep it from cracking in freezing weather. A drain valve is available from WATERAX (item no 250269).

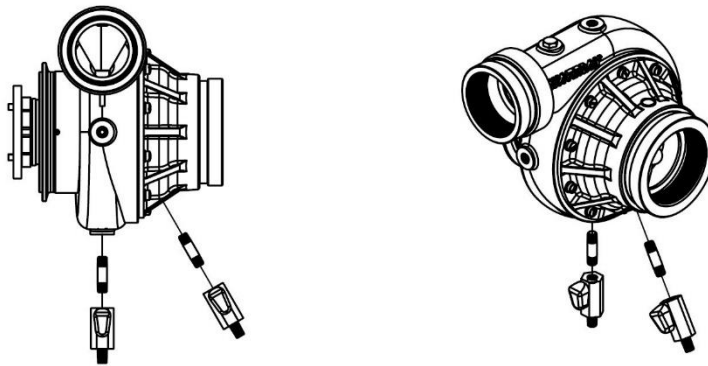

## Fastening to Truck/Apparatus

When adding any equipment to a vehicle, follow all instructions and heed all warnings provided by manufacturers of the apparatus and any third-party accessories. WATERAX provides certain accessories used in vehicle-mount configurations of the B2X series pumps. Follow all documentation that ships with any accessories you have ordered such as vibration mounts or rails. Your company's internal policies and guidelines must also be followed.

Before installing the pump in a vehicle, plan for adequate access to any fill caps such as those for oil, fuel or coolant (if applicable), as well as any other part of the pump or engine that is frequently accessed or inspected (valves, panels, primers, filters, etc.). Make note of components that become hot when operating such as mufflers and engine blocks, and always ensure a safe clearance around them.

## Installing a Control Panel

See User Instructions shipped with the specific model of control panel you ordered for your pump.

## Using a Battery for Electric Starters and Control Panels

Some B2X pumps require a battery to power electrical and electronic components such as starters, pump primers and control panels. Make sure to follow all instructions and heed all warnings provided by your battery manufacturer. Refer to the engine manual for battery and wiring requirements. Always follow safety guidelines set out by your company. Never connect or disconnect a battery to a pump that is operating.

Recommended minimum standards for battery cables:

- 6 AWG x 5 ft maximum length (15 mm<sup>2</sup> x 1.5 m)
- 4 AWG x 7.5 ft maximum length (20 mm<sup>2</sup> x 2.3 m)

## Supplying Fuel to the Engine

B2X pumps without an integrated fuel tank must be connected to a safety-compliant fuel tank. Follow your company's guidelines on connecting fuel lines to gas- or diesel-operated pumps. Always use safe work practices in the presence of flammable products such as fuel.

# OPERATING B2X SERIES PUMPS

## Pre-Operation Checklist

Before using your pump, follow this verification procedure:

1. Visually inspect product.  
When you first receive your B2X pump, inspect the product and check for any damage. Notify the supplier if any damage is found.
2. Check all fluid levels regarding the pump and any related equipment. Before first use, you must prepare the engine which is shipped dry. Before each subsequent use, check levels and top up as needed.
  - Engine/apparatus fuel level
  - Engine/apparatus oil level
  - Engine/apparatus coolant level (if applicable)
  - All batteries electrolyte level (not required for sealed batteries)



**Important:** Refer to the engine manufacturer's manual for specific instructions regarding the engine.

3. Check that all suction and discharge hoses are structurally sound and do not leak.
4. Visually inspect any electrical or electronic components for damage.
5. Inspect all safety features and verify that they are in good order before using the pump.
6. Inspect muffler rain cap if equipped and verify that it is working properly, **as water infiltration can cause damage to the engine.**
7. Visually inspect the pump's drive belt and ensure it is in good condition without cracks or excessive wear.
8. Each time you plan to use the pump, check for damage that may have occurred during previous use. Notify your manager that the equipment requires repair. Remember that damaged equipment can expose you to safety hazards.

## Flooded Suction

Use this procedure if you are taking water from a hydrant, another pump, or a closed tank. Be sure to understand and follow all related equipment, apparatus, departmental, and governmental procedures, policies, recommendations, and guidelines concerning hydrant connecting and operation before performing this mode of operation.

1. Connect the intake hose to the pump intake or intake piping.
2. Connect opposing end of the hose to the hydrant or water source (a tank may already be connected). Make sure that all connections are strong and tight and that all pump valves are closed.
3. Check that all equipment is rated to the proper pressure limits that they will be exposed to during this mode of operation. DO NOT exceed the maximum intake pressure of the pump (150 PSI).
4. Slowly open the pump inlet valves allowing the water into the pump body.
5. Slowly open the discharge valves to allow for entrapped air in the piping to escape.
6. Once all the air has escaped, close any opened valves so that the unit may be started.
7. Go to the *Startup and Discharge* section of this manual to begin pumping water.



**Important:** The pump will not discharge more water than the capacity of the water source (hydrant). The pressure reading on the pump's master intake gauge should never fall below 0 PSI during the pump operation in this mode.

## Drafting

### Before you draft

Pumps should not be run dry, and therefore the pump ends require priming prior to operation. If equipped with an exhaust primer, refer to section "Priming the Pump". Use this procedure if you are drafting water from an open tank or natural water source. To maintain optimum performance from your pump, follow these recommendations for selecting and installing your suction hose or pipe:

- Use the shortest length possible, i.e., place the pump as close to the water as possible.
- Select reinforced crush resistant (non-collapsible) hose or pipe.
- Make sure that all pipes have air tight fittings.
- To avoid air locks, flexible hose should rise gently from the water source to the suction/inlet port without excessive dips, bumps, sharp angles or rise in its lay.
- Pipes should be equal to or larger than the diameter of the suction/inlet port.
- Suction strainers should be fitted to prevent foreign matter from entering the pump.
- Where practicable, the installation and use of a suction float will aid in the performance of your pump, by keeping suction away from the debris on the bottom of the dam or river.
- Ensure that the suction hose is completely submersed.

### Limitations

Several factors can affect the pump's ability to efficiently draft water. The following limitations should be taken into account.

- Water temperatures above 35 °C (95 °F) can cause noticeable loss in pump performance.
- Barometric pressures below 98 kPa (29 in of Hg) can also cause noticeable loss in pump performance (specifically elevations >2000 feet above sea level).
- Pump performance curves are based off a 5 foot lift (top of water source to impeller center). Lifts greater than 5 feet will decrease the pump's performance.
- Hose and strainer sizes that are too restrictive can significantly decrease the pump's performance.
- Intake hose runs in excess of 10 feet can also reduce pump performance.

### Drafting connections

1. Connect a suction line to the pump intake.
2. Install a foot valve suction strainer on the other end of the suction hose and place in the water source.



**Important:** To provide proper operation of the pump, the suction hose/strainer should be submerged a minimum of 4 to 6 times the hose diameter into the water source.

**DO NOT** run pump dry.

**DO NOT** allow foot valve strainer to rest on bottom of lake or riverbed. Check strainer frequently to make sure that it is not clogged with moss, leaves, etc.

**DO NOT** lift strainer from water while the pump is operating. Use a rope or other means to keep strainer at proper height, approximately 1 foot (30 cm) below water surface. If strainer is too close to the water surface, it will draw air and pump may lose prime.

## Priming the Pump

Before priming the pump, discharge hoses should be installed. Several options are available to prime a pump when you are drafting water, depending on the priming equipment you have.



**Important:** The priming line must be connected to a port on the pump that allows the eye of the impeller to completely fill with water. A shut off valve should also be placed between the pump and the primer to shut off the priming line once the pump has been primed.

### WATERAX Hand Primer

Connect hand primer to discharge port and pump until water is drawn into the pump.

### Manual Priming

If suction hose is equipped with a foot valve:

1. Open the priming cap and fill pump with water manually.
2. Firmly tighten priming cap.
3. Pump can also be primed by “jerking” the suction hose until water flows from the pump’s discharge port.

### Guzzler Priming

1. Open the priming valve (located under the check valve on portable units).
2. On vehicle mount units, ensure that the discharge valves are closed.
3. Pump until water is drawn into the pump.

### Electric Priming

See instructions for your electric primer. Note that most electric primer motors are intended to be used only for a short duration of time (about 20 seconds). If pump fails to prime, see the troubleshooting section.

### Exhaust Priming

With the engine running (see *Startup and Discharge* section):

1. Open priming valve.
2. Adjust THROTTLE to full speed position.
3. Close and press down firmly on muffler-lever-handle or pull priming knob (if supplied with a panel mount control panel) until a solid stream of water flows from priming ejector.

**Pump should not take more than 30 seconds to prime. Operating longer than this time period can overheat the pump seal and significantly lower its service life.**

4. **Close the priming valve** and re-open the muffler-lever-handle/butterfly valve. The check valve (on portable units) will open automatically under the water pressure when priming occurs.

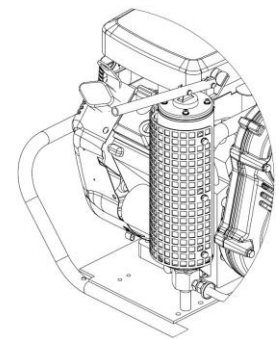
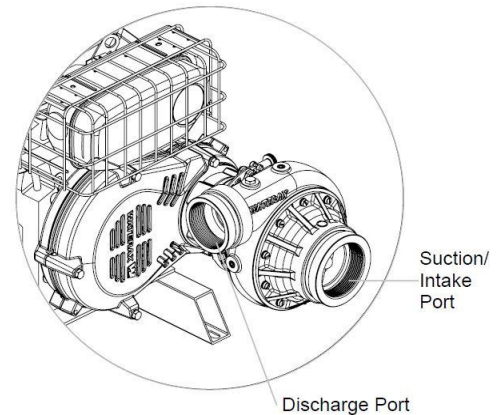

5. **Slowly** open a discharge valve to validate that the pump has been primed. If pressure does not build in the discharge hose, the pump has not been fully primed. The valve should be closed and the pump primed again. Continue this process until the pump has been fully primed.
6. Reduce throttle setting and allow engine to warm up for at least 2 minutes before using full throttle.



**Important: Close the priming valve after priming.** Failure to close the priming valve could cause the pump to lose prime or water to be pumped through the priming system.

## Startup and Discharge

1. Fill fuel tank with recommended fuel grade.
  - a) For models with an integral fuel tank, fill tank and securely replace cap.
  - b) For models without an integral fuel tank, fill external fuel tank and connect fuel supply line to the fuel filter. Pump fuel to fill supply line. For the diesel pump model, refer to the engine manual for fuel system air bleeding instructions.

2. Start the engine.

For B2X-18, B2X-23, and B2X-21:

Pump must be primed before running the engine for any period of time longer than 30 seconds (see “Priming the Pump” section).

- a) With all discharge valves closed, turn the on/off ignition key or switch to the “ON” position. For B2X-21H equipped with a *WATERAX* control panel, set the key switch to “OFF” and remove from ignition.
- b) Open fuel valve.
- c) Close/engage choke, if engine is cold.
- d) Increase the throttle past the idle position.
- e) Start the engine using the key switch or the start button. Hold until engine starts. **DO NOT HOLD** for more than 5 seconds. If starting using the rewind starter, ensure that the key switch or ignition switch is on the “ON” position. Give starter rope a quick and steady pull until engine starts.
- f) Open/disengage choke
- g) Allow engine to warm up for a minimum of 2 minutes before using full throttle.

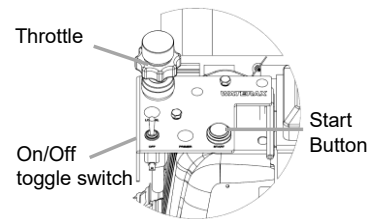

For B2X-D902 using the PMSCP-DIESEL control panel:

If equipped with a LOFA control panel, refer to LOFA's Panel Operation and Troubleshooting Guide for instructions.

- a) Push the control panel's ON/OFF button. A green ring on the button will light up indicating that the panel is powered. You can now use the electric primer if equipped (see Priming section).
- b) Warm up: The electric starter's glow plugs require a 10-second warm-up period which begins as soon as you push the ON/OFF button on the control panel. During the warm-up period, the START button is deactivated and the engine cannot be started. As soon as the warm-up period is over, the low oil pressure (  ) light will turn on, indicating that the engine is ready to start.

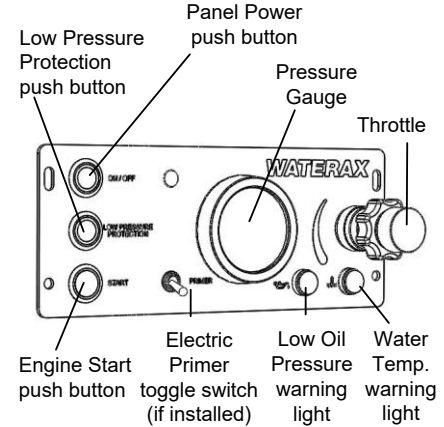

**Important:** If low oil pressure light does not turn off after engine has started, stop the engine and check the oil level.

- c) Make sure all discharge valves are closed.
- d) Once the pump is primed, push and hold the START button until the engine starts.
- e) Turn the Vernier throttle counter-clockwise to increase engine speed past the idle position. Pressure should build up in the system.
- f) Press the LOW PRESSURE PROTECTION button to activate the protection. If pressure drops below 7 psi (loss of prime condition), the engine will automatically shut down to protect the pump.



**Important:** Leaving the pump running with all the discharge valves closed is called deadheading the pump. The pump should not be left in this mode for more than a minute. Leaving in this condition for any length of time will cause the pump to overheat and damage the pump. To avoid overheating the pump, a re-circulation line (if provided) should be opened or a discharge line left slightly open to allow fresh water to continue to enter the pump.

### 3. Discharge water.

Once the pump is primed, and with the engine running, you can begin to discharge water.

- a) Slowly open the discharge valve. If pressure does not build in the discharge hose, the pump has not been fully primed. The valve should be closed and the pump primed again.
- b) Adjust the pump performance by throttling the engine up or down, or opening or closing discharge valves at various positions, or any combination of the two.

## Shutdown

1. After completing the pump operation, gradually reduce the engine RPM and slowly close the discharge valves (preferably in the order listed).
2. Whenever the unit has been run at full throttle for most of the operation, allow the valves to remain slightly open and run the engine at idle for approximately 5 minutes before shutting down the unit.
3. If the pump was last run with foam or water that is salty, brackish or high in mineral content, flush the pump with fresh water for a minimum of 2 minutes or until the water is clear.
4. Close off the hydrant or water supply to the pump.

5. Open all valves to relieve any pressure left in the system.

## Cold Weather Operation

The pump can be run in below freezing temperatures if certain precautions are taken to avoid the formation of ice in the pump.

1. After priming the pump, the unit should be run at low speed for a short period of time to allow all components to warm up before continuing with the remaining operating procedures.
2. Unless wrapped in a heater, drain the pump of all water if it is stopped for any length of time. The engine/drive unit should be turned over a few revolutions to make sure all water has been removed from the pump. Drain the pump priming line if a primer has been used.
3. After use, drain the pump, manifolds, and lines of all water. You can also pour some environmentally safe antifreeze into the pump and circulate it through the pump and plumbing system.

## Basic Care and Storage

The basic care described in this section does not require any disassembly of the pump. For any servicing procedures that require removing any part of the pump to access a component, please see the **Error! Reference source not found.** section.



**Warning:** Before doing any maintenance to the pump, always ensure that the equipment cannot be accidentally started. Follow any apparatus and/or departmental procedures or guidelines regarding locking out the equipment.

### Regular maintenance

After each use:

1. Visually inspect the pump unit.
2. Make sure the mechanical rotary seal is not leaking.
3. Check the pump for external leaks.
4. Check the engine for leaks.
5. Check the condition of the flexible buffer coupling. Replace if worn. See instructions for removing the pump end from the engine using the quick release pump clamp.
6. Clean any dirt or debris from the pump unit. If necessary, a mild soap and water solution can be used.
7. Note and report any performance irregularities or any abnormal mechanical sounds.
8. Check all fluid levels and add as needed.
9. Make sure all necessary tools, spares, and accessories are with the pump.

### Long-term storage

1. Completely drain the pump of all water.
2. Drain the carburetor. The engine can be run with the fuel valve lever in the OFF position to drain the system.
3. Drain the fuel tank (if applicable).
4. Close all valves and plug all openings.
5. Follow any other products, components, apparatus, and departmental procedures and/or guidelines before placing the unit in storage.

## Troubleshooting

This section provides brief troubleshooting instructions for verifying the set-up and operation of the pump. Each section describes a condition and lists possible causes along with a list of items to check to identify the source of the problem and resolve it.

### Pump Loses Prime or Will Not Prime

---

<b>Air Leaks</b>	<p>Attempt to locate and correct the air leaks by isolating each system component.</p> <ul style="list-style-type: none"> <li>■ Disconnect the pump priming system and test. Check that the priming system is pulling its rated vacuum.</li> <li>■ Cap the pump discharge and prime the pump. If the pump primes, the leak is in the pump discharge components. If the pump does not prime, the leak may be in the pump, or the pump intake system.</li> <li>■ Cap the pump intake and discharge and then perform a vacuum test on the pump (15 to 30 in Hg). If the prime holds, then the leak is in the pump intake components. If the pump does not hold prime, leakage could come from a port or drain line attached to the pump.</li> <li>■ Before repeating the test above, disconnect the drain line from the pump and plug. If the pump holds vacuum, the leak is in the drain line or drain valve. If the pump does not hold prime, leakage could be from another component attached to a port in the pump.</li> <li>■ Before repeating the test above one last time, remove any other component connection from the pump and plug. Re-test the pump under vacuum. If the pump holds prime, leakage was in one of the components removed. If the pump does not hold prime, leakage is in the pump.</li> </ul>
<b>Air Trapped in Suction (Pump Intake) Line</b>	<ul style="list-style-type: none"> <li>■ Check that no part of the suction hose or piping is higher than the pump intake. Pump suction hose and piping must be laid out with a continuous decline to the water source from the pump intake.</li> <li>■ If the pump intake piping above the pump intake cannot be avoided, priming taps must be added to the raised section of piping for the removal of trapped air.</li> <li>■ If the suction hose cannot be laid out in a manner to avoid raised sections in the hose, wiggle and raise the hose while priming to allow the entrapped air to work its way from the raised region.</li> <li>■ Check the priming port location. If the port is not located in a position that will allow the eye of the impeller to fill with water, it will need to be moved to a location that will do so.</li> </ul>
<b>Blocked or Restricted Intake Hose or Strainer</b>	<ul style="list-style-type: none"> <li>■ Remove blockage from the intake hose or strainer.</li> <li>■ Strainer should not be sitting at the bottom of the water source where debris can be picked up. Clean off the strainer and raise to a position that is off the bottom of the water source (floating strainers are available).</li> <li>■ If the strainer is new, check that the strainer hole size is not too restrictive for the demands of the pump.</li> </ul>
<b>Pump Suction Lift Requirements are Too High</b>	<ul style="list-style-type: none"> <li>■ DO NOT attempt pump lifts exceeding 22 feet (6.7 meters) except at elevations lower than 2000 feet (610 meters) above sea level.</li> <li>■ As elevation increases above 2000 ft (610 meters) above sea level, maximum lift height will diminish. Check that the lift for the elevation the pump is being required to operate at is achievable.</li> </ul>
<b>Inoperative Priming System</b>	<ul style="list-style-type: none"> <li>■ Check and service the priming system as outlined in the documentation from the priming system's supplier.</li> </ul>



**Pump Does Not Meet Performance**

---

<b>Incompatible Suction Hose</b>	<ul style="list-style-type: none"> <li>■ Piping size and configuration may be too restrictive. Contact a WATERAX Inc. representative if assistance is needed in evaluating the unit's piping.</li> </ul>
<b>Gauge or Instrument Failure</b>	<ul style="list-style-type: none"> <li>■ Check that all gauges are calibrated, and that all equipment is in proper condition. Nozzles with dented edges and bent or damaged pitot tubes will produce faulty readings</li> </ul>
<b>Blockage</b>	<ul style="list-style-type: none"> <li>■ Check all hoses, tank, piping, etc. Remove any obstructions found.</li> <li>■ Check for debris wedged or caught in the impeller or diffusers. Remove any obstructions found.</li> </ul>
<b>Insufficient Power to the Pump</b>	<ul style="list-style-type: none"> <li>■ Check engine compression and complete engine repairs if required.</li> <li>■ An engine will lose approximate 3.5% of its power per every 1000 feet above sea level. If the elevation of operation was not considered when the unit was selected, a unit of higher horsepower may be required to make the needed performance</li> </ul>
<b>Restriction</b>	<ul style="list-style-type: none"> <li>■ If a new strainer and/or intake hose was purchased, check that they provide adequate supply to the pump to meet the performance desired.</li> <li>■ If the pump was purchased used, check that the actual configuration will achieve the desired performance. A WATERAX Inc. representative can be contacted for assistance.</li> <li>■ Check pump lift. Refer to "Pump Loses Prime or Will Not Prime: Suction Lift Too High" section.</li> </ul>

**Pump Cavitating**

---

<b>Lift Too High</b>	<ul style="list-style-type: none"> <li>■ Move pump closer to water source.</li> <li>■ Decrease pump's intake hose length.</li> <li>■ Increase pump's intake hose size (inner diameter).</li> </ul>
<b>Water Temperature</b>	<ul style="list-style-type: none"> <li>■ Water temperature may be too high. Water temperatures approaching 35°C (95°F) or higher are likely to cavitate the pump. Decrease engine speed and/or gate the discharge valve to decrease pump flow until the cavitating stops.</li> <li>■ Locate a cooler water source.</li> </ul>
<b>Restrictions</b>	<ul style="list-style-type: none"> <li>■ Refer to "Restrictions" in the "Pump Does Not Make Performance" section.</li> <li>■ Check that the bottom of the suction hose is at a minimum of 2 feet (0.6 meters) from the bottom of the water source and correct if necessary.</li> <li>■ Check that the bottom of the suction hose/strainer is 4 to 6 times the hose diameter below the water supply surface level and correct if necessary.</li> </ul>

**Engine Speed Too High for Required Capacity and Pressure**

---

<b>Air Leaks</b>	<ul style="list-style-type: none"> <li>■ Refer to "Pump Loses or Will Not Prime: Air Leak" section.</li> </ul>
------------------	--



# SERVICE

This section includes instructions for overhaul and maintenance requiring disassembly of the WATERAX 2-stage pump end that is integrated in the B2X series pumps. It does not include engine maintenance. For maintenance instructions regarding the engine, as well as for oil and fuel recommendations, please refer to the engine manufacturer's manual.

**Important:** It is recommended that all fasteners be replaced with genuine WATERAX parts.

## Drive Assembly Parts Breakdown

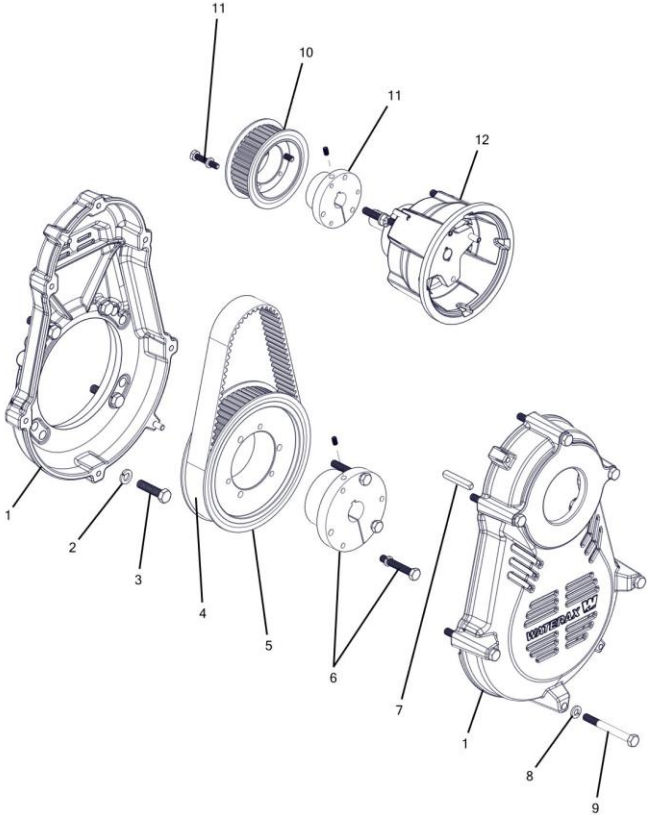

ID	ITEM NO	DESCRIPTION	QTY
1	701670	SPEED INCREASER HOUSING PAINTED	1
2	800512	FAST-502 LOCKWASHER 3/8 SPLIT ZINC	4
3	800485	FAST-524 SCREW 3/8-16X1-1/2 HEX CAP ZINC	4
4	800803	PART-1 TIMING BELT,8MMP X 30W X 720LG	1
5	800825	PART-2 PULLEY 64T X 8MM P X 30MM W	1
6	801011	PART-4 BUSHING FOR 1" SHAFT	1
	801264*	BUSHING FOR 1-1/8" SHAFT SK	
	801234**	BUSHING FOR 1-7/16" SHAFT SK W/HARDWARE	1
7	600176	PART-7 KEY 1/4"SQUARE, S.S.	1
8	800513	FAST-501 LOCKWASHER 5/16 SPLIT ZINC	6
9	800534	FAST-1 SCREW 5/16-18X3 HEX CAP ZINC DICHROMATE	6
10	800856	PART-3 PULLEY 34T X 8MM P X 30MM W	1
11	800852	PART-5 BUSHING FOR 3/4" SHAFT	1
12	600633	DRIVE CARRIER ASSEMBLY COMPLETE	1

\* The bushing is available for engine with 1-1/8" shaft  
 \*\* The bushing comes in the diesel pump end kits

Figure 1: Exploded view of drive assembly

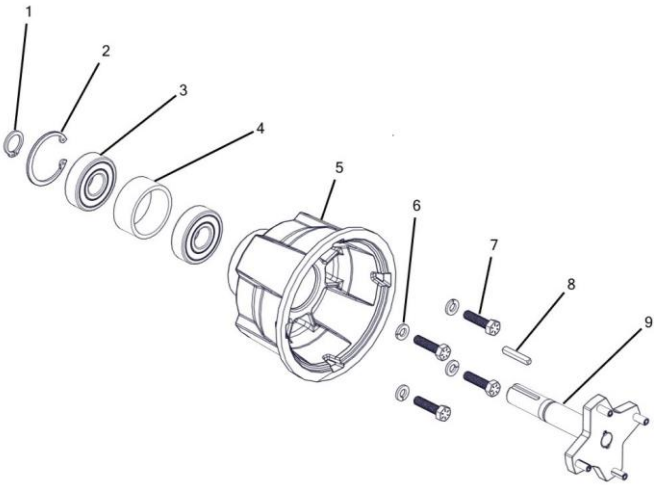

ID	ITEM NO	DESCRIPTION	QTY
--	600633	DRIVE CARRIER ASSEMBLY COMPLETE	--
1	800538	PART-8 RETAINING RING EXT.	1
2	800541	PART-9 RING RETAINING INT.	1
3	800836	PART-10 BEARING, 4 POINT CONTACT, SEALED	2
4	700083	A-6956 SPACER FOR C-7220, ALU.	1
5	701672	SPEED INCREASER HUB PAINTED	1
6	800513	FAST-501 LOCKWASHER 5/16 SPLIT ZINC	4
7	701907	SCREW 5/16-18X1-1/4 HEX CAP FULL THREAD ZINC	4
8	600151	PART-6 KEY 3/16" SQUARE, SS	1
9	700086	A-7239 SHAFT ASSEMBLY FOR C-7220	1

Figure 2: Exploded view of drive hub assembly (item no 600633)

### Installing the Drive Assembly

**Before Installation**

- Read and follow all instructions thoroughly and carefully.
- Ensure shaft, bores, screws, etc. are free of burrs and lubricant.

**Tools and Materials Required**

- Torque wrench
- SAE Socket wrench with the following sockets to be used on the drive box cap screws and bushing cap screws:
  - 7/16"
  - 1/2"
  - 9/16"
- SAE Allen keys to be used on the bushing set screws:
  - 1/8" or 3/32"
  - 5/32"
- Medium-strength threadlocker solution (e.g. Loctite® 243)
- Speed Increaser tools:

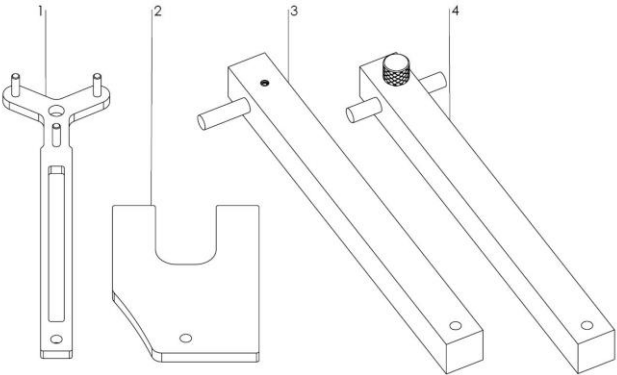

ID	ITEM NO	DESCRIPTION	QTY
1	600617	SPEED INCREASER SPROCKET HOLDING TOOL	1
2	600620	SPEED INCREASER POSITIONING TOOL - DRIVEN	1
3	600619	SPEED INCREASER POSITIONING TOOL - DRIVER	1
4	600618	SPEED INCREASER VERIFICATION TOOL	1

**Procedure – Driven Sprocket (Pulley)**

1. Install the Drive Hub Assembly (**600633**) onto the front cover of the Speed Increaser.

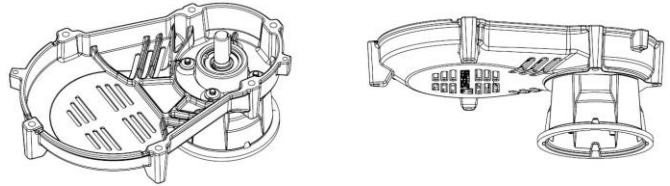

2. Use the DRIVE ASSY POSITIONING TOOL - DRIVEN (**600620**) to position the driven bushing onto the shaft. The bushing shoulder should sit flush on the positioning tool. Insert the key. Make sure they key runs the entire length of the bushing bore.

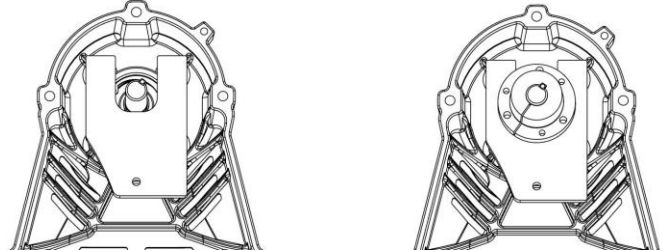

3. Apply medium-strength Loctite® 243 on the set screw. Install and **hand tighten only**. This will lock the bushing position.

4. Slide out the DRIVE ASSY POSITIONING TOOL – DRIVEN.

5. Install the Driven Sprocket onto the bushing. Align the non-threaded holes of the sprocket with the threaded holes of the bushing.

6. Use a torque wrench to gradually tighten the cap screws with lock washers sequentially until each is tightened to **108 in-lbs**. When the cap screw is at the recommended torque value, make at least two more sequential rounds to ensure all cap screws are at the adequate torque value.

Use the DRIVE ASSY SPROCKET HOLDING TOOL (**600617**) to prevent the sprocket from turning while torquing the screws.

TIGHTEN SCREWS WITH TORQUE WRENCH

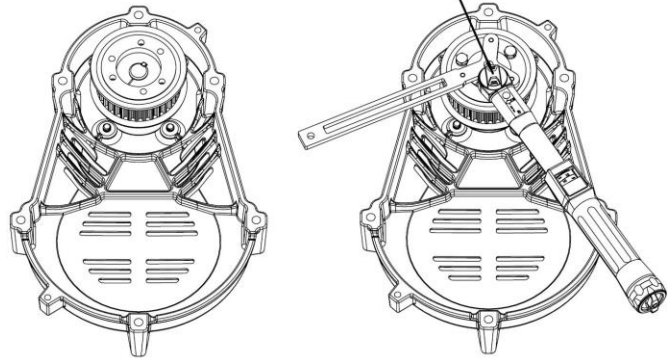

**Procedure – Driver Sprocket (Pulley)**

7. Place the rear cover on engine. Make sure the rear cover is properly positioned and lying flat against the engine face. Securely tighten the four cap screws and lock washers.

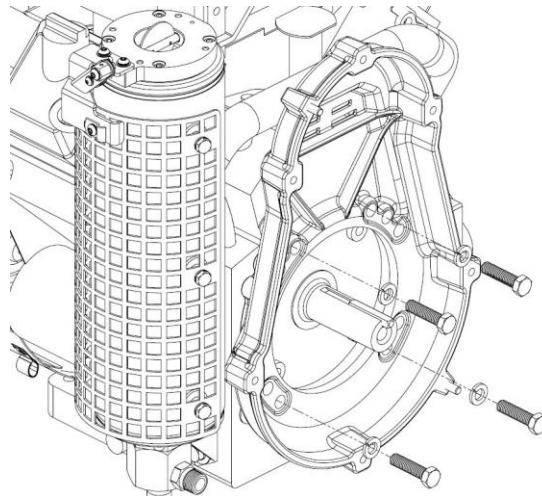

8. Align the non-threaded holes of the bushing to the threaded holes of the driver sprocket. Insert the cap screws into the threaded holes of the pulley and turn them by hand three to four turns.
9. Put the bushing and driver sprocket on the shaft and align the keyways.
10. Insert the key. Make sure the key runs the entire length of the bushing bore.
11. Use the DRIVE ASSY POSITIONING TOOL - DRIVER (600619) to position the sprocket and bushing.

**Note:** If reinstalling the sprocket, the mechanic may need to do minor adjustments. To help keep the position of the sprocket and bushing correct, make a mark on the engine shaft where the bushing and shaft meet. This is where the bushing and sprocket must be once tightened.

12. Apply medium strength thread locker such as Loctite® 243 on the set screw. Install and **hand tighten only**. This will lock the bushing position.
13. Using a torque wrench and the appropriate socket, tighten the cap screws with lock washers sequentially until each is tightened to **180 in-lbs**.

You can use the Sprocket Holding Tool to keep the sprocket from turning while tightening the screws. You can also use the rewind starter (when available) to lock the engine shaft.

When the cap screw is at the recommended torque value, make at least two more sequential rounds to ensure all cap screws are at the adequate torque value.

14. Use the DRIVE ASSY VERIFICATION TOOL (600618) to make sure the two sprockets are at the correct position. Position the Verification Tool on top of the driven sprocket. Loosen the thumb screw and push the "A" side of the pin until it touches the front cover lip of the Speed Increaser. Tighten the thumb screw.

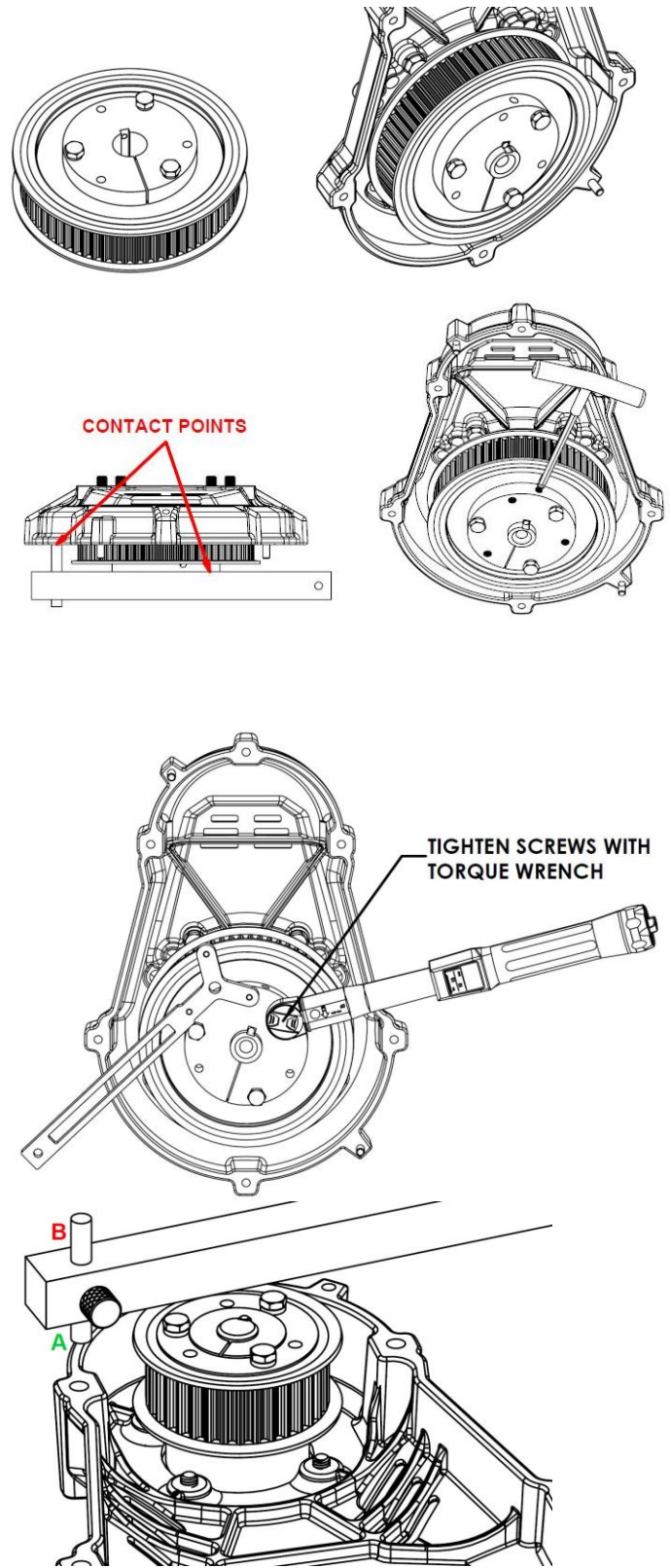

15. Place the Verification Tool onto the Driver Sprocket and check if the "B" side of the pin touches the back cover; that position is good. There is a play of up to 1/16".

If the pin exceeds or comes short of the cover by more than 1/16", note the distance on the engine shaft and bushing, remove and re-install the bushing and pulley assembly using the above steps.

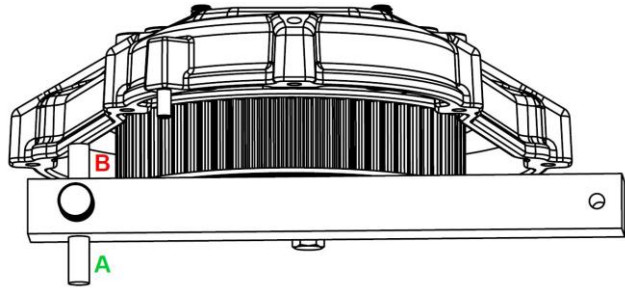

**Procedure – Belt & Front Cover**

16. To install the front cover, loop the timing belt around the small driven sprocket. Make sure the timing belt is seated properly on the sprockets.
17. Align the top dowel pin with the corresponding hole on the front cover, and partially insert the front cover onto the dowel pin.
18. Using the top dowel pin as a pivot point, swing the front cover and align the second dowel pin with the corresponding hole.
19. Insert the front cover fully onto the dowel pins and flat against the back-cover mating surface.
20. Fasten the front cover and the rear cover using the six cap screws and lock washers. To help seat the cover properly, tighten the top screw, then the bottom screw, and then alternate the screws on either side, crisscrossing the cover. Securely tighten.

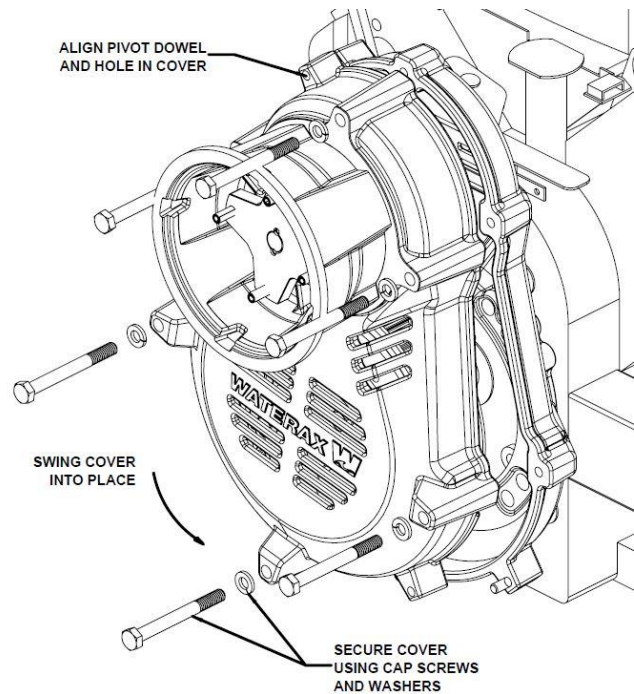

 **Warning:** Make sure you take all safety precautions specified for your engine.

## Removal of Pulley Assembly

1. Remove all the cap screws sequentially.
2. Remove the set screw.
3. For the large driver pulley, insert the cap screws into the threaded holes of the bushing. For the small driven pulley, insert the cap screws into the threaded holes of the pulley.
4. Tighten the cap screws against the face until the screw force releases the pulley from the bushing.

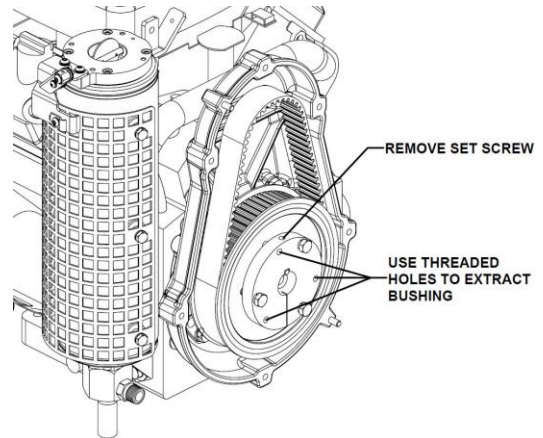

## Removing or Attaching the Pump End

All of the B2X series pump ends have a quick release pump clamp and detachable pump end which facilitates the servicing of pump units and minimizes down-time in the field by allowing the quick replacement of pump ends.

### To remove pump from engine:

1. Lift pump clamp lever.
2. Release tension-adjusting knob.
3. Remove clamp by tapping top end of each half clamp.
4. Remove pump from engine.

### To attach the pump end to the engine:

1. Place flexible buffer coupling on engine coupling pins.
2. Align flexible buffer coupling holes to pump end coupling pins and install.
3. Install pump clamp with the lever on the top side.  
Finger tighten tension knob to obtain a light pressure on clamp ring.

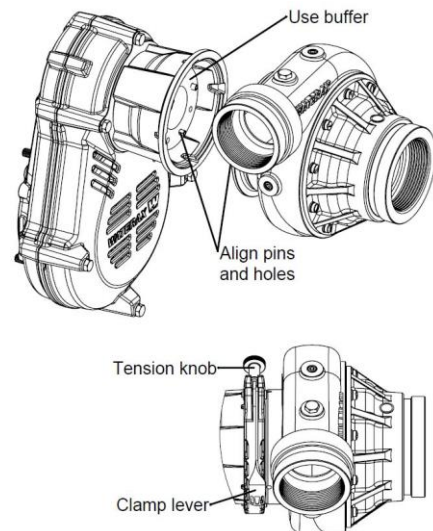

**Important:** Apply FINGER PRESSURE ONLY to close pump clamp lever. Excessive pressure will damage or break the clamp link.

**B2X Portable Frame Assembly**

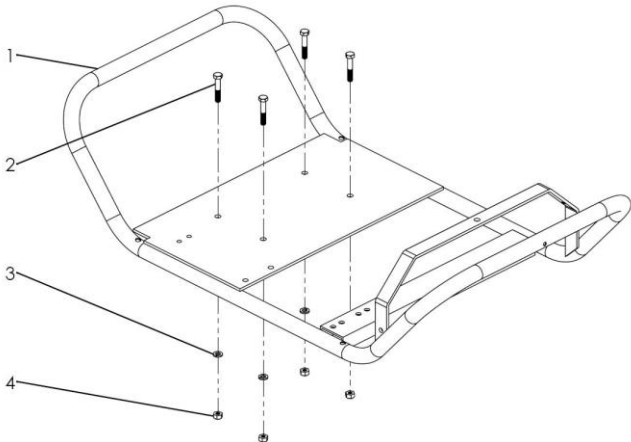

ID	ITEM NO	DESCRIPTION	QTY
1	700094	B-7591 BB-4 FRAME, USDAFS	1
2	800531	FAST-15 SCREW 5/16-18X1-3/4 HEX CAP ZINC	4
3	800513	FAST-501 LOCKWASHER 5/16 SPLIT ZINC	4
4	800523	FAST-352 NUT 5/16-18 HEX ZINC	4

**B2X-23 Low Tone Mufflers**

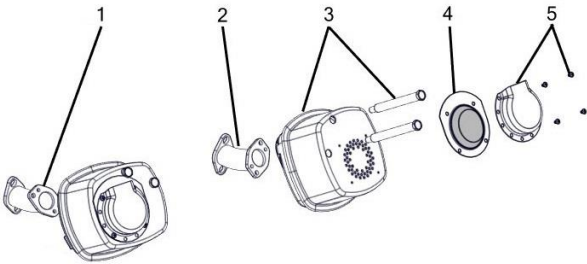

ID	ITEM NO	DESCRIPTION	QTY
1	800136	BRIGGS-222573 MUFFLER DEFLECTOR	2
2	800143	BRIGGS-392390 SPARK ARRESTOR USE ON B1-11-HP	2
3	800144	BRIGGS-399635 LOW TONE MUFFLER F/18IC ENGINE	2
4	700060	A-7577 MANIFOLD RH, LOW TONE MUFFLER B&S 23	1
5	700059	A-7576 MANIFOLD LH, LOW TONE MUFFLER B&S 23	1

**B2X-18 Low Tone Mufflers**

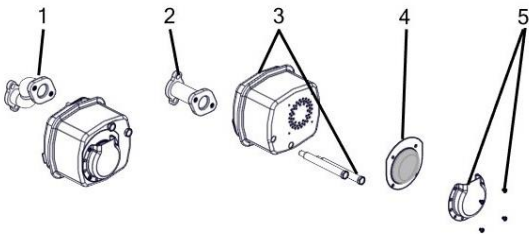

ID	ITEM NO	DESCRIPTION	QTY
1	800136	BRIGGS-222573 MUFFLER DEFLECTOR	2
2	800143	BRIGGS-392390 SPARK ARRESTOR USE ON B1-11-HP	2
3	800144	BRIGGS-399635 LOW TONE MUFFLER F/18IC ENGINE	2
4	700107	C-7593R MANIFOLD RH, LOW TONE MUFFLER B&S 18	1
5	700085	C-7593L MANIFOLD LH, LOW TONE MUFFLER B&S 18	1

**Guzzler Primer**

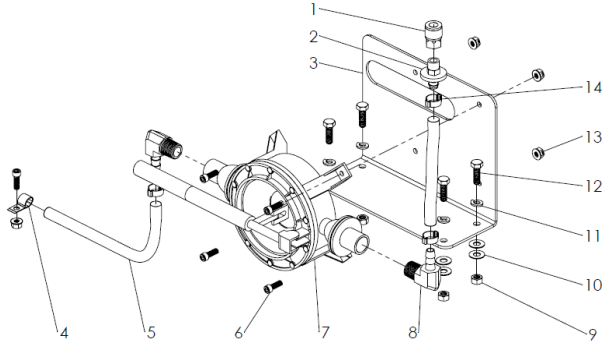

ID	ITEM NO	DESCRIPTION	QTY
1	800649	PART-475 COUPLER QD F TO 1/4" NPTF	1
2	800833	PART-129 COUPLER 1/4 NPTM TO 3/8" BARB	1
3	700078	A-7700 GUZZLER PRIMER MOUNTING BRACKET	1
4	800408	B-5562-18 CLAMP PLASTIC COATED 9/16" ID	1
5	800855	QHOSRUB3/8BL HOSE 3/8"ID, BLACK	2.5
6	800383	FAST-744 SCREW 1/4-20X1/2 HEX SOCKET SS	5
7	800737	BOS-400-H-1/2 GUZZLER HAND PRIMER, 1/2 NPT	1
8	800706	PART-316 ELBOW BRB 3/8 TO MNPT 1/2.BR	2
9	800307	FAST-540 NUT 5/16-18 HEX SS	4
10	800302	FAST-535 WASHER 5/16 FLAT SS	4
11	800312	FAST-545 LOCKWASHER 5/16 SPLIT SS	4
12	800385	FAST-561 SCREW 5/16-18X1 HEX CAP SS	4
13	800419	C-6650-14 NUT 1/4-20 FLANGED DISTORTED LOCKNUT	5
14	800749	PART-388 OETIKER DOUBLE EAR CLAMP .544" TO .669"	3

**Check Valve Assembly**

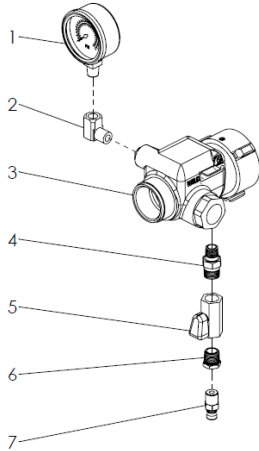

ID	ITEM NO	DESCRIPTION	QTY
1	700122	GAUGE-1 PRESSURE GAUGE 2-1/2"-600PSI (BAR)	1
2	800719	C-4067-5 ELBOW 1/4 NPT M. TO FEM	1
3	600428	B-6365 CHECK VALVE ASSEMBLY 1-1/2"NPSH	1
4	800823	PART-147 RED. NIPPLE 3/8NPT TO 1/4NPT	1
5	800780	PART-348 VALVE BRASS MINI 3/8 NPT, WEDGE	1
6	800819	PART-190 RED. BUSHING 3/8 TO 1/4 FM NPT	1
7	800660	PART-474 NIPPLE QD M TO 1/4" NPTM	1

**B2X Priming System**

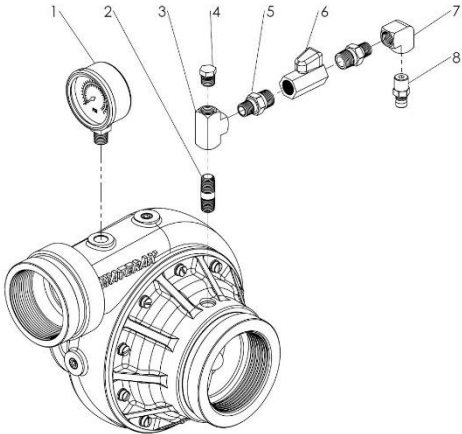

ID	ITEM NO	DESCRIPTION	QTY
1	700122	GAUGE-1 PRESSURE GAUGE 2-1/2"0-600PSI (BAR)	1
2	800798	PART-243 NIPPLE LONG 1/4" NPT X 1.5"	1
3	800748	PART-373 TEE 1/4 NPT FEM BRASS	1
4	700614	B-6365-11 PLUG 1/4" NPT, BRASS	1
5	800823	PART-147 RED. NIPPLE 3/8NPT TO 1/4NPT	2
6	800780	PART-348 VALVE BRASS MINI 3/8 NPT, WEDGE	1
7	800799	PART-244 ELBOW 90 DEG FEM X FEM 1/4"NPT	1
8	800660	PART-474 NIPPLE QD M TO 1/4" NPTM	1

### EPA/CARB 1 US Gal Fuel Tank Assembly

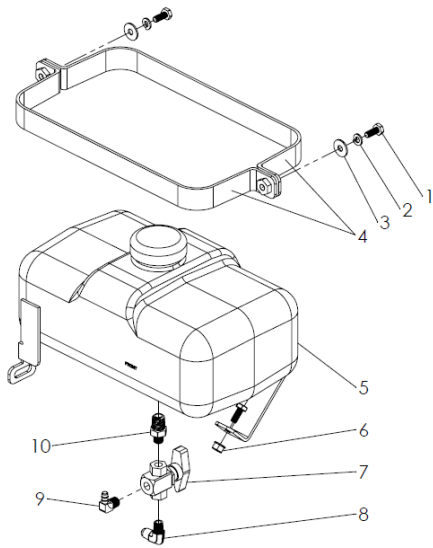

ID	ITEM NO	DESCRIPTION	QTY
1	800431	FAST-727 SCREW 1/4-20X5/8 HEX CAP ZINC	3
2	800428	FAST-728 LOCKWASHER 1/4 SPLIT ZINC	2
3	800543	R-151 WASHER 1/4 FLAT ZINC	2
4	700516	A-7688 FUEL TANK BRACKET BB-4	1
5	700627	PART-370 EPA/CARB 1 GAL FUEL TANK	1
6	800427	FAST-729 NUT 1/4-20 HEX NYLON LOCK ZINC	1
7	800796	PART-24 1/8 -3WAY VALVE	1
8	800817	PART-169 ELBOW 1/4" TUBE(SAE45) TO 1/8NPT	1
9	800716	C-6700-28 ELBOW 1/8"NPT M. TO 1/4" HOSE	1
10	800761	PART-406 HX NIPPLE 1/4MPT TO 1/8MPT	1

### Work Light Assembly

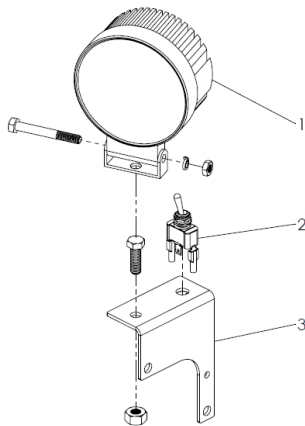

ID	ITEM NO	DESCRIPTION	QTY
1	800987	PART-365 WORK LIGHT 27W LED W/HARDWARE	1
2	800914	PART-378 SWITCH TOGGLE DPDT 20A ON-ON	1
3	700272	A-7694 TRPD WORK LIGHT BRACKET TM	1

### Engine Mount Control Panel

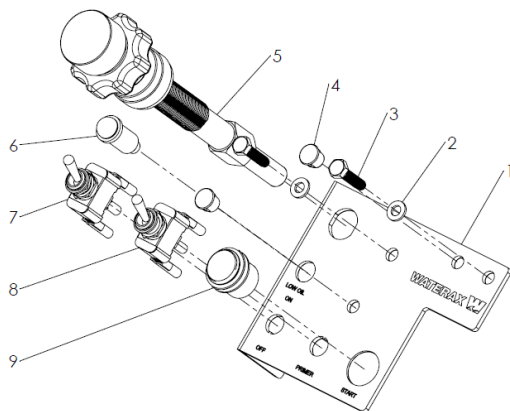

ID	ITEM NO	DESCRIPTION	QTY
1	700051	A-7721 ENGINE MOUNT CTRL PANEL FRAME	1
2	800474	D-5269-7 WASHER 1/4 FLAT SS	2
3	800525	FAST-21 SCREW M6X1.0X25 HEX CAP ZINC	2
4	800433	PART-524 PLASTIC PLUG 0.375" HOLE, BK	2
5	800673	PART-454 VERNIER THROTTLE CABLE (3100)	1
6	800926	PART-455 RED LED INDICATOR 12V, .500"H	1
7	800914	PART-378 SWITCH TOGGLE DPDT 20A ON-ON	1
8	800904	PART-381 SW TOGGLE, SPST, 15A, OFF-(ON)	1
9	800924	PART-472 PUSH BUTTON DPST 4P,(ON)-OFF	1

**Electric Primer Assembly**

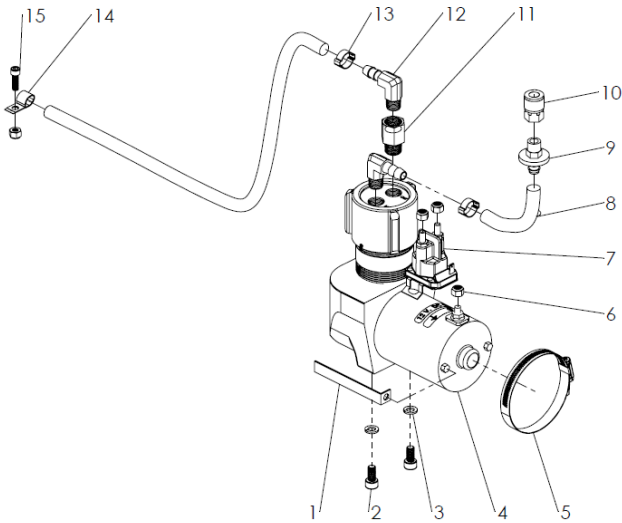

ID	ITEM NO	DESCRIPTION	QTY
1	800149	BRIGGS-691532 GROUNDING STRAP	1
2	800336	FAST-746 SCREW M8X1.25X16 HEX SOCKET SS	2
3	800548	R-119 LOCKWASHER M8 SPLIT ZINC	2
4	600067	B-7498 ELECTRIC PRIMER	1
5	700695	PART-272 WORM HOSE CLAMP 2-9/16"-3-1/2"	1
6	800296	FAST-528 NUT 1/4-20 HEX NYLON LOCK SS	4
7	800135	BRIGGS-691656 SOLENOID	1
8	800790	QHOSEPVC38 HOSE 3/8 ID,BRAIDED PVC	4
9	800833	PART-129 COUPLER 1/4 NPTM TO 3/8" BARB	1
10	800649	PART-475 COUPLER QD F TO 1/4" NPTF	1
11	700596	B-6601W-27 ADP 3/8" M. NPT TO 3/8"FEM NPT	1
12	800703	PART-315 ELBOW BRB 3/8 TO MNPT 3/8, BR	2
13	800749	PART-388 OETIKER DOUBLE EAR CLAMP .544" TO .669"	2
14	800408	B-5562-18 CLAMP PLASTIC COATED 9/16" ID	1
15	800383	FAST-744 SCREW 1/4-20X1/2 HEX SOCKET SS	1

**Exhaust Primer Assembly**

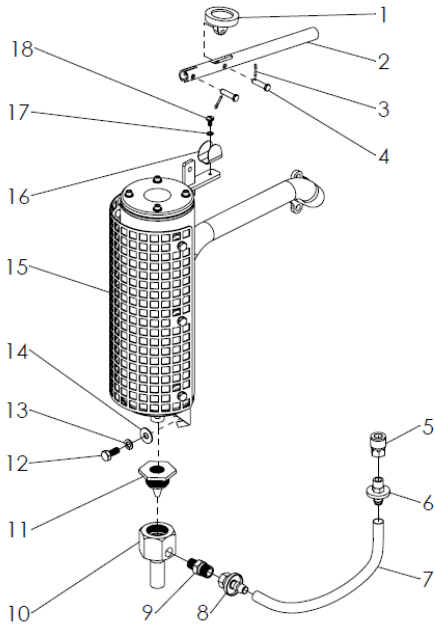

ID	ITEM NO	DESCRIPTION	QTY
1	700077	A-7242 HANDLE CAP FOR C-6890, BRONZE	1
2	600028	B-7241 MUFFLER HANDLE LEVER FOR C-6890, PLATED	1
3	800465	B-2428-8 COTTER PIN 3/32" X 1/2" LG, SS	2
4	800483	FAST-706 CLEVIS PIN 1/4" X 27/32"LG	2
5	800649	PART-475 COUPLER QD F TO 1/4" NPTF	1
6	800833	PART-129 COUPLER 1/4 NPTM TO 3/8" BARB	1
7	800855	QHOSRUB3/8BL HOSE 3/8"ID, BLACK	2.5
8	800696	A-6751-5 SWIVEL 45DEGRES SAE	1
9	700635	C-6750-20 ADP 1/4" NPT M. TO 3/8" TUBE	1
10	700019	A-4584 BODY EJECTOR FOR A-4585, BRASS	1
11	700028	A-4585 NOZZLE CONE FOR A-4583, BRASS	1
12	800520	R-414 SCREW M8X1.25X20 HEX CAP CADM	1
13	800548	R-119 LOCKWASHER M8 SPLIT ZINC	1
14	700071	C-5370-11 WASHER 7/8"OD X 11/32"ID X 1/16"TH, S.S.	1
15	600097	C-7590 MUFFLER FOR BB-4-23VG, PAINTED	1
16	600113	A-7243 LEVER CLAMP FOR C-6890 MUFFLER, S.S.	1
17	800511	FAST-504 LOCKWASHER #10 SPRING SS	1
18	800563	FAST-6 SCREW #10-24X3/8 PHILLIPS BINDING SS	1



**Battery Kit**

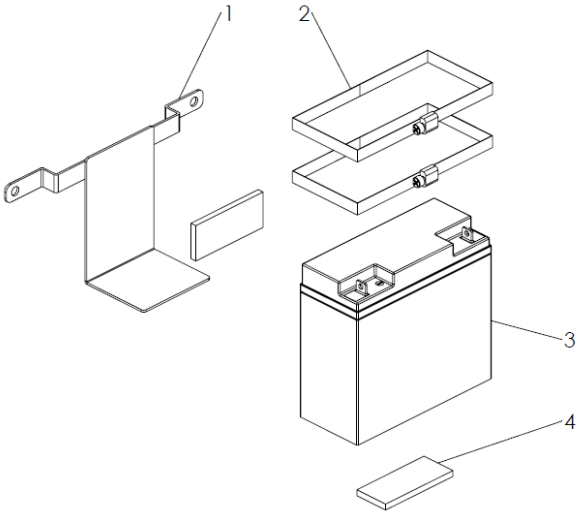

ID	ITEM NO	DESCRIPTION	QTY
1	600126	A-7645 WELDED BATTERY BRACKET PAINTED	1
2	800846	PART-93 HOSE CLAMP, GEAR TYPE,S/S	2
3	700673	PART-764 VRLA SEALED BATTERY 12V 20AH	1
4	800844	QF-5458-3 SPONGE 1/4"THK X 1-1/2W (25'/ROLL)	0.58

**Vehicle Mount Frame Assembly**

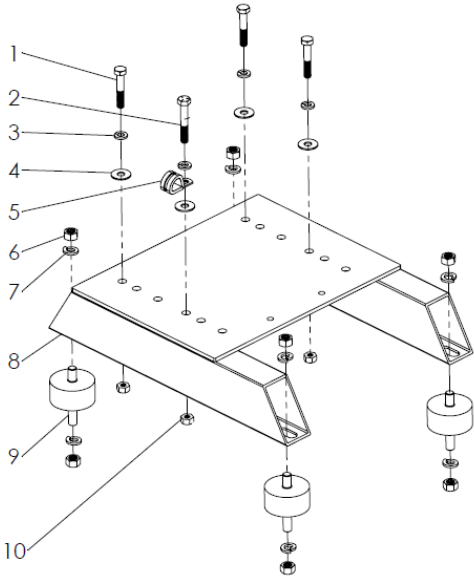

ID	ITEM NO	DESCRIPTION	QTY
1	800531	FAST-15 SCREW 5/16-18X1-3/4 HEX CAP ZINC	3
2	801281	SCREW 5/16-18X2 HEX CAP ZINC	1
3	800513	FAST-501 LOCKWASHER 5/16 SPLIT ZINC	4
4	700071	C-5370-11 WASHER 7/8"OD X 11/32"ID X 1/16"TH, S.S.	4
5	800840	PART-33 WIRE CLAMP 1/2" BLACK	1
6	800308	FAST-541 NUT 3/8-16 HEX SS	8
7	800305	FAST-538 LOCKWASHER 3/8 SPLIT SS	8
8	700139	A-7654 PUMP FRAME, SKIDTANX	1
9	800768	PART-311 VIBRATION MOUNT, SKID	4
10	800523	FAST-352 NUT 5/16-18 HEX ZINC	4



Exhaust Primer Assembly for Vehicle Mount

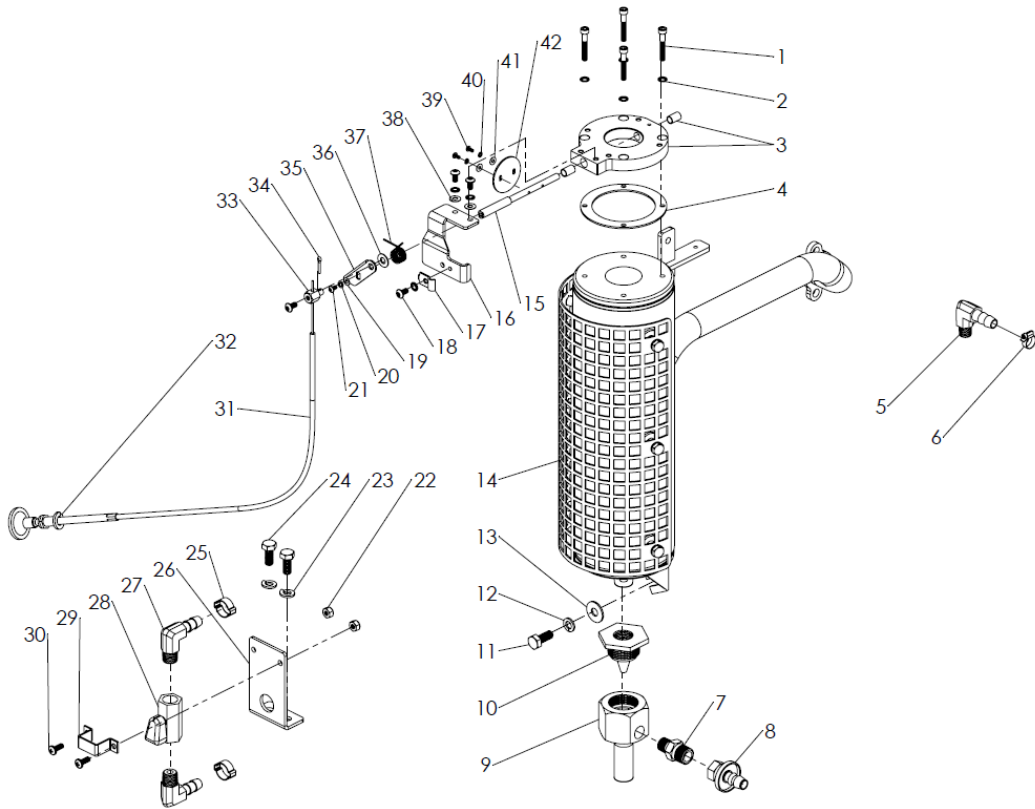

ITEM NO	DESCRIPTION	QTY
1	800330 FAST-762 SCREW #10-32X1 HEX SOCKET SS	4
2	800511 FAST-504 LOCKWASHER #10 SPRING SS	7
3	600352 B-7594-4 BODY ASSEMBLY REMOTE EXHAUST PRIMER	1
4	700753 A-7611 GASKET INTERIOR FOR BB-4 EXHAT	3
5	800671 PART-750 ELBOW BARB 3/8 X 1/8NPTM	1
6	800647 RK-1842 HOSE CLAMP 1/2"OD	1
7	700635 C-6750-20 ADP 1/4" NPT M. TO 3/8" TUBE	1
8	800696 A-6751-5 SWIVEL 45DEGRES SAE	1
9	700019 A-4584 BODY EJECTOR FOR A-4585, BRASS	1
10	700028 A-4585 NOZZLE CONE FOR A-4583, BRASS	1
11	800520 R-414 SCREW M8X1.25X20 HEX CAP CADM	1
12	800548 R-119 LOCKWASHER M8 SPLIT ZINC	1
13	700071 C-5370-11 WASHER 7/8"OD X 11/32"ID X 1/16"TH, S.S.	1
14	600097 C-7590 MUFFLER FOR BB-4-23VG, PAINTED	1
15	700693 B-7594-5 SHAFT, REMOTE EXHAUST PRIMER	1
16	700609 B-7594-7 BRACKET, CABLE MOUNT	1
17	700504 PART-761 CLAMP, CABLE EXH. PRIMER	1
18	800335 FAST-769 SCREW #10-32X3/8 HEX SOCKET BUTTON HD SS	4
19	800337 FAST-766 WASHER #6 FLAT SS	1
20	800339 FAST-767 LOCKWASHER #6 SPLIT SS	1
21	800333 FAST-765 SCREW #6-32X1/2 HEX SOCKET BUTTON HEAD SS	1

ID	ITEM NO	DESCRIPTION	QTY
22	800421	FAST-732 NUT #10-24 HEX NYLON LOCK ZINC	2
23	800312	FAST-545 LOCKWASHER 5/16 SPLIT SS	2
24	800304	FAST-550 SCREW 5/16-18X3/4 HEX CAP SS	2
25	800749	PART-388 OETIKER DOUBLE EAR CLAMP .544" TO .669"	2
26	700061	A-7690 BALL VALVE BRACKET EXHAUST PRIMER SKIDTANX	1
27	800703	PART-315 ELBOW BRB 3/8 TO MNPT 3/8, BR	2
28	800780	PART-348 VALVE BRASS MINI 3/8 NPT, WEDGE	1
29	700062	A-7691 SQUARE CLAMP EXHAUST PRIMER SKIDTANX	1
30	700316	COR-1200-025 PAN HD SCREW #10-24 X1/2LG S/S	2
31	700520	PART-763 PUSH-PULL CABLE 12' EXH. PRIMR	1
32	800305	FAST-538 LOCKWASHER 3/8 SPLIT SS	1
33	700521	A-7594-8 CABLE STOP REMOTE EXH. PRIMER	1
34	800465	B-2428-8 COTTER PIN 3/32" X 1/2" LG, SS	1
35	700690	B-7594-10 LEVER, REMOTE EXHAUST PRIMER	1
36	800321	FAST-768 WASHER 1/4 FLAT BRASS	1
37	800376	PART-759 SPRING TORSION .556"OD, 270DEG	1
38	800318	FAST-763 WASHER #10 FLAT SS	2
39	800324	FAST-759 SCREW #4-40X1/4 HEX SOCKET BUTTON HEAD SS	2
40	800327	FAST-761 LOCKWASHER #4 SPLIT SS	2
41	800326	FAST-760 WASHER #4 FLAT SS	2
42	700691	B-7594-6 DISC, REMOTE EXHAUST PRIMER	1



**B2X Pump End Parts Breakdown**

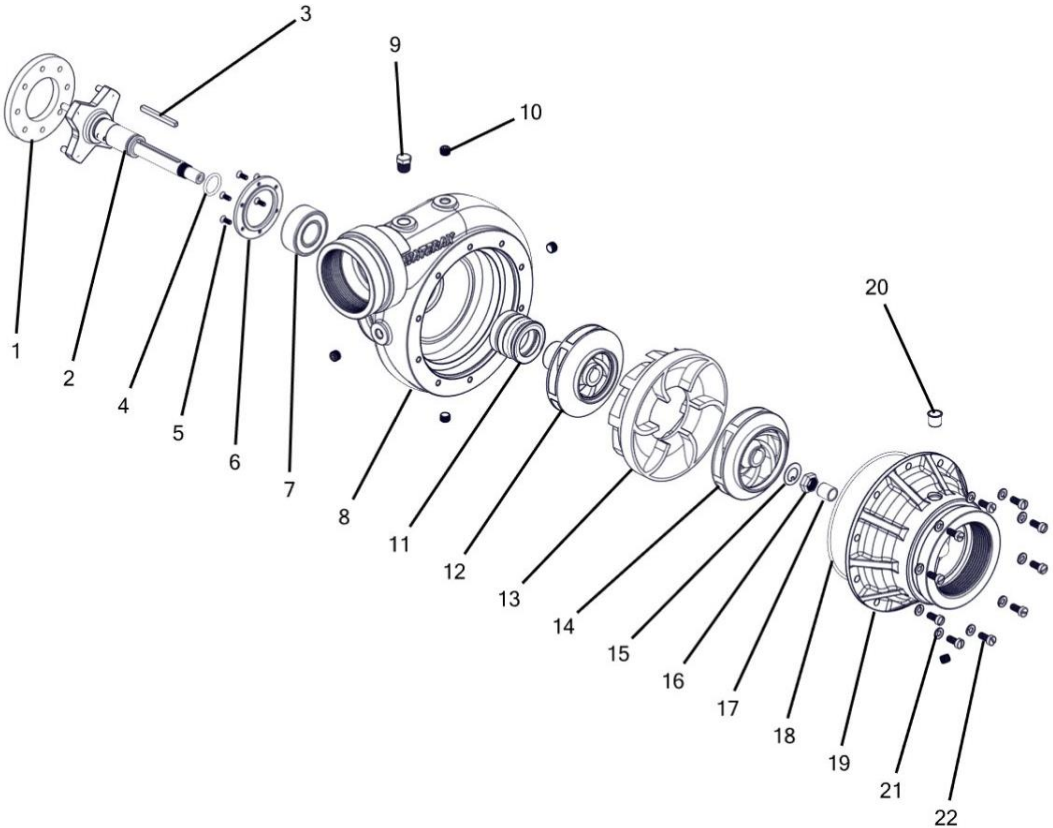

ID	ITEM NO	DESCRIPTION	QTY
1	700006	12-17 COUPLING BUFFER	1
2	700038	B-7034-1 PUMP SHAFT FOR B-2	1
3	600065	C-7030-16 KEY FOR B2 PUMP, S.S.	1
4	700633	C-6600-21 O-RING, NITRILE.	1
5	800364	12-25 SCREW #8-32X7/16 PHILLIPS FLAT NYLON LOCK SS	6
6	700032	12-3 RETAINING RING FOR BEARING, ALUM.	1
7	700044	12-48S DOUBLE ROW BALL BEARING WITH SEAL	1
8	600024	C-7037 BODY PUMP B2X, ALU. ANODIZED	1
9	700614	B-6365-11 PLUG 1/4" NPT, BRASS	1
10	800366	12-73 PLUG, 1/8" BRASS	5
11	700063	C-6600-9C ROTARY SEAL SILICON CARBIDE	1

ID	ITEM NO	DESCRIPTION	QTY
12	600523	A-7038 2 <sup>ND</sup> IMPELLER FOR B-2 AND B2X, ALU.	1
13	600039	B-7039 DISTRIBUTOR B-2, ALU. ANODIZED	1
14	600016	B-7038 1 <sup>ST</sup> IMPELLER B2X, ALU. ANODIZED	1
15	600089	12-49 LOCKWASHER SS	1
16	700012	12-50 LOCK NUT SS	1
17	700634	C-6600-23 BEARING BUSHING PLAIN SLEEVE 1/2"	1
18	800782	C-7030-10 O-RING	1
19	600025	B-7041 SUCTION COVER B2X, ALU. ANODIZED	2
20	800658	PART-508 PLASTIC PULL PLUG FOR 1/4" NPT	1
21	800360	12-38 LOCKWASHER 1/4" SPLIT SS	10
22	800359	12-39 SCREW 1/4" -28X9/16 SLOT FILLISTER SS	10



## Disassembly Procedure for B2X Pump End

1. Remove screws #22 and lockwashers #21.
2. Remove suction cover #19.
3. Bend down lockwasher #15 from locknut #16. Secure the shaft #2 from rotating and remove lock nut using a 19 mm (3/4") wrench. Discard lockwasher.
4. Remove O-ring #18, impeller #14, distributor #13 and impeller #12. The rotating part of the mechanical rotary seal will come out with the impeller.
5. Remove screws #5.
6. Using an arbor press and a shaft protector, press out the shaft assembly #2. (Shaft protector: WATERAX item no 700532). Remove key #3.
7. Remove the stationary part of the seal that is inside the pump body. ***It is recommended to replace the mechanical rotary seal at each maintenance disassembly.***
8. To remove bearing from shaft, use an arbor press and a bearing puller. (Pump bearing extractor tool: WATERAX item no 600123).
9. Remove bushing #17 from suction cover only if replacement is needed. Using a 1/4" NPT tap, thread into the bushing a few turns and pull out.



**Important:** It is recommended to discard all O-rings, lockwashers and nylon lock screws.

## Assembly Procedure for B2X Pump End



**Important:** Smear the O-rings with a suitable lubricant to facilitate assembly.

1. Slide bearing retaining ring #6 with plain face toward coupling collar.
2. Press bearing #7 on shaft. (Pump bearing pressing sleeve: WATERAX item 600052).
3. Install O-ring #4 on shaft.
4. Install the seal #11 stationary seat.



**Important:** Protect precision lapped faces of new seal from damage, dirt and finger marks. NEVER use grease or heavy oil as an installation lubricant. Any oil or grease on the seal faces may cause the seal to leak.

- a. Carefully install the stationary part of the seal inside the pump body. Make sure the seal is well seated at the bottom of the seal seat in the pump body. The silicon carbide face should be facing the top of the pump body.
  - b. Clean the sealing face of the seal with a lint free tissue and alcohol to remove any contaminant.
5. Carefully pass end of shaft assembly through rotary seal bore in the pump body. Gently press down the shaft until the ball bearing rests firmly against shoulder.





6. Attach retaining ring #6 to pump body with six screws #5 to a torque value of 22-25 in-lbs. / 2.5-2.8 Nm. Tighten evenly.
7. To avoid the soap from drying, proceed quickly with the next steps. Apply a light amount of diluted liquid dish soap (e.g., DAWN®) solution on the impeller outside shaft surface and seal bellows, and install the rotating part of the seal on the impeller. Gently press down to compress the spring. The seal should move up and down freely.
8. Clean the sealing face of the seal with a lint free tissue and alcohol to remove any contaminant.
9. Carefully flip over the impeller with the seal and slide it onto shaft. The impeller should move up and down freely.
10. Install key #3 onto shaft.
11. Install distributor #13.
12. Slide impeller #14 onto shaft.
13. Place lockwasher #15 on shaft with locating tab in milled groove. Slightly bend lockwasher tab downwards to facilitate insertion. Lockwasher tab should still prevent it from rotating on shaft.
14. Apply a small amount of Loctite 290 on lock nut #16 and screw onto shaft with flat surface facing lockwasher. Tighten to a torque value of 250-260 in-lbs. / 28-29 Nm. To secure lock nut and prevent from rotating, bend one side of hexagon lock nut. Bend the lockwasher side that is at the opposite side of the milled slot in the shaft.
15. Place O-ring #18 on the groove of the pump body. The O-ring will sit between the distributor and the pump body. Ensure that the O-ring is seated properly before installing the suction cover.
16. Apply a light amount of copper anti-seize on the suction cover bearing bushing and install suction cover #19 using screws #22 and lockwashers #21. Tighten screws evenly and firmly to a torque value of 32-36 in-lbs. / 3.6-4.1 Nm.

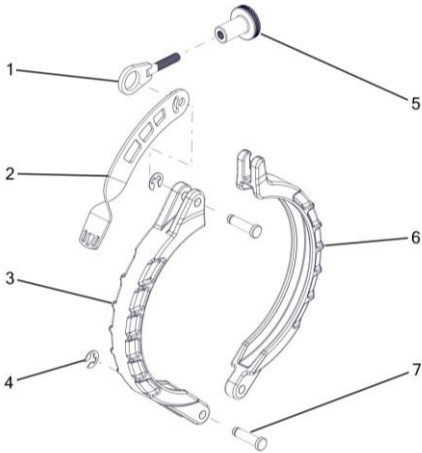

**Pump Clamp**

ID	ITEM NO	DESCRIPTION	QTY
--	600630	PUMP CLAMP ASSEMBLY WATSON	--
1	701851	LINK CLAMP WATSON	1
2	701852	LEVER CLAMP WATSON	1
3	701782	CLAMP HALF AIR BOX SIDE WATSON	1
4	702260	RETAINING RING EXTERNAL RADIAL 1/4" SS	2
5	701810	THUMB SCREW CLAMP WATSON	1
6	701784	CLAMP HALF MUFFLER SIDE WATSON	1
7	702261	CLEVIS PIN GROOVED 1/4" X 29/32" LG SS	2





**Important:** The quick release pump clamp should be inspected on a regular basis. If components appear to be worn, replace them immediately.

**Assembly of B2X-D902 Stub Shaft and Engine Housing**

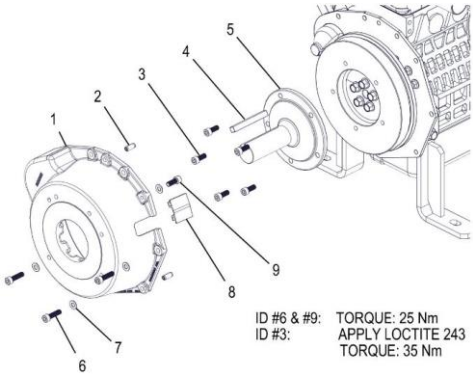

ID	ITEM NO	DESCRIPTION	QTY
1	600572	BELL HOUSING K106 ALU SAE "A" PILOT, HARDWARE INCL	1
2	--**	GUIDING PIN	2
3	--*	SCREW M8 X 20 HEX SOCKET	5
4	600582	KEY 3/8" SQUARE X 3-1/4" LG, STEEL	1
5	600571	STUB SHAFT FORGED K106 1-7/16 X 5, HARDWARE INCL.	1
6	--**	SCREW M8 X 30 HEX SOCKET	3
7	--**	FLAT WASHER M8	4
8	--**	PROTECTIVE COVER	1
9	--**	SCREW M8 X 20 HEX SOCKET	1

\* Parts come included in kit 600571  
 \*\* Parts come included in kit 600572



Assembly of B2X-D902 Air Filter

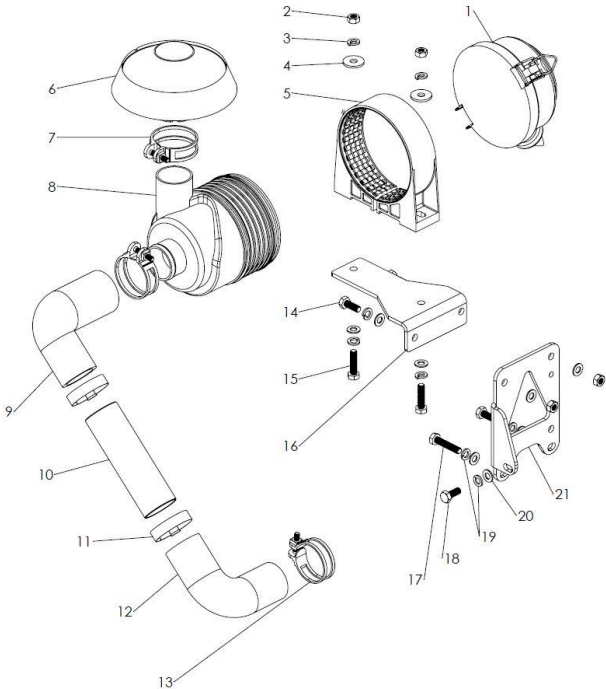

ID	ITEM NO	DESCRIPTION	QTY
1	--*	1G657-11011-3 ASSY CLEANER, AIR	1
2	--*	02156-50080 HEX. NUT	4
3	--*	04512-50080 WASHER, SPRING LOCK	6
4	--*	04015-50080 WASHER, PLAIN	2
5	--*	1G657-11011-1 ASSY CLEANER, AIR	1
6	--*	RAIN CAP, KUBOTA	1
7	--*	15221-11722 BAND, PIPE	2
8	--*	1G657-11011-2 ASSY CLEANER, AIR	1
9	--*	1G952-11621-2 HOSE, INLET	1
10	701211	SLEEVE 1-3/4"OD X .125"TH X 5.5"LG ALU	1
11	801225	HOSE CLAMP DOUBLE WIRE 2-1/2"	2
12	--*	1G952-11621-1 HOSE, INLET	1
13	--*	15261-11721 BAND, PIPE	1
14	--*	01123-50822 BOLT, SEMS	2
15	--*	01123-50832 BOLT, SEMS	2
16	--*	1G659-11571 STAY, AIR CLEANER	1
17	801229	SCREW M8X1.25X40 HEX CAP ZINC	2
18	800520	R-414 SCREW M8X1.25X20 HEX CAP CADM	1
19	800548	R-119 LOCKWASHER M8 SPLIT ZINC	3
20	800539	R-206 WASHER M8 FLAT ZINC	9
21	701210	BRACKET MAIN SUPPORT FOR AIR CLEANER, SS	1

\* Parts included in kit 801248 (air filter); Kubota D902 parts



### Assembly of B2X-D902 Engine High Temp Sending Unit

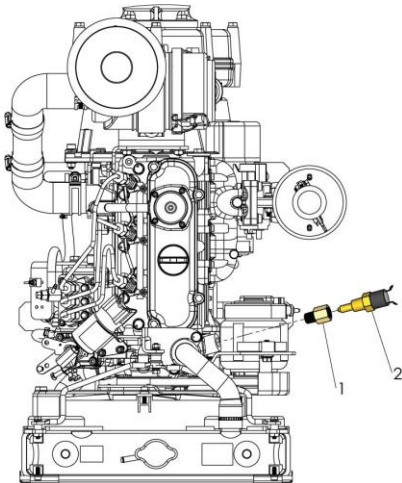

ID	ITEM NO	DESCRIPTION	QTY
1	801252	ADAPTER BUSHING 3/8" FNPT TO 3/8" MBSPT HEX BRASS	1
2	801232	TEMPERATURE SENDER & SWITCH 120 DEG	1

### Assembly of B2X-D902 Low Oil Pressure Sending Unit

The following parts are required if equipped with LOFA Control Panel EP250G7 (250280)

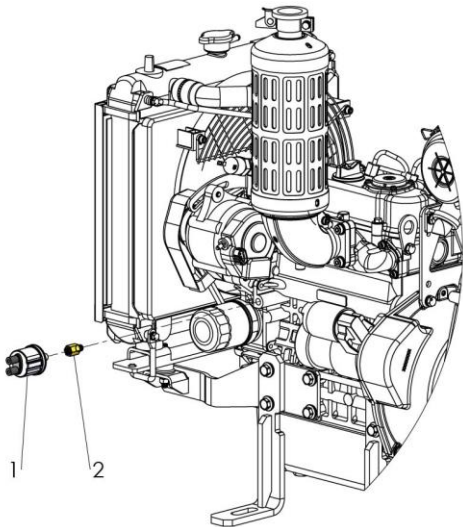

ID	ITEM NO	DESCRIPTION	QTY
1	801251	LOW OIL PRESSURE SENDER & SWITCH FOR ENGINE	1
2	801253	ADAPTOR BUSHING 1/8" FNPT TO 1/8" MBSPT HEX BRASS	1
-	800890	PART-526 LOW PRESSURE CUTOUT SWITCH 7PSI	1
-	701391*	LOW PRESSURE CUTOUT SWITCH 20 PSI	1

\*The optional 20 PSI is chosen to match the USDA Spec' for the 643P and 643U models

**Installation:**

1. Remove oil pressure switch that comes pre-installed on the Kubota D902 engine.
2. Install the adaptor bushing (2).
3. Install the oil pressure sender (1).

(Note: Use sealing tape or putty to create a good seal on all tapered threads)

**Wiring:**

Refer to FASTWIRE Wiring Diagram section (Wiring for Diesel Pump).  
*Note: All blunt wires are found at the end of the FASTWIRE harness.*

**A - OIL PRESSURE SENDER:**

1. Connect the yellow/orange wire (M) to the “WK” stud on the Oil Pressure Sender.
2. Connect the orange wire (E) to the “G” stud on the Oil Pressure Sender.

**B - LOW WATER PRESSURE PROTECTION SWITCH:**

*An extension might be required from the FASTWIRE harness to the Low Water Pressure Protection Switch.*

1. Connect the yellow wire (K) to one of the terminals on the Low Water Pressure Protection Switch (AUX. SHUTDOWN 1)
2. Connect the black wire (blunt) to the remaining terminal on the Low Water Pressure Protection Switch (GND).

**B2X Wiring****Standard WATERAX wiring configuration:**

All vehicle B2X pumps are wired from the factory to work with an XCP control panel. To revert to the original engine controls, refer to the next section for instructions.

**XCP vs. Engine Controls:**



A WATERAX XCP control panel will NOT work correctly if the Honda engine mounted control box key is in the “ON” position. Therefore, when a WATERAX XCP panel is used with the unit, the key should be turned in the “OFF” position and then removed from the engine. It is recommended that it be stored somewhere and not kept with the engine to avoid any operator from mistakenly turning the Honda control box on.

**Warning LED Indicators:**

The B2X-21H (GX630) comes equipped with a Honda Engine Controls Box (ECB) which has a Low Oil LED indicator. When operating the pump with an XCP control panel, the Honda ECB Low Oil LED will turn on when the stop toggle switch or the Low Pressure Protection turns off the engine. The Honda ECB Low Oil LED indicator MUST be ignored. To turn off the ECB Low Oil LED, cut the power to the engine. **Only the warning indications on the XCP panel are to be considered when operating the pump with an XCP panel.**

**Original Engine Wiring Configuration:**

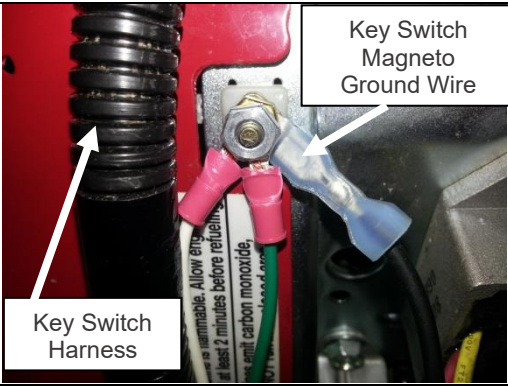
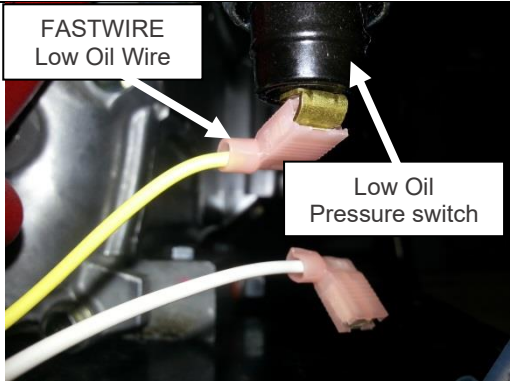
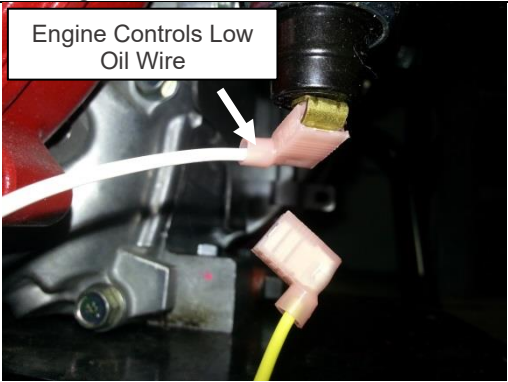
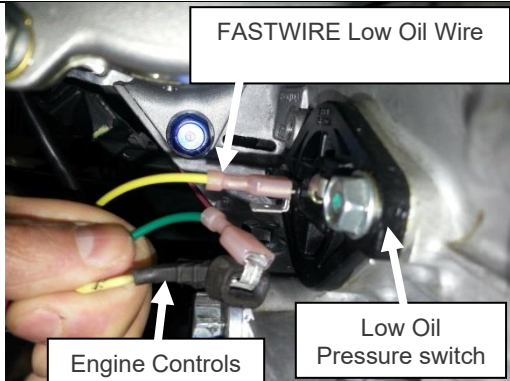
To revert back to the Original Engine Controls refer to the instructions below (does not apply to B2X-D902).

ENGINES	FOR XCP	FOR ENGINE CONTROLS
<p style="writing-mode: vertical-rl; transform: rotate(180deg);">BRIGGS &amp; STRATTON 18/23 HP</p>	<p>Magneto Grounding Stud</p> 	<p>Key Switch Magneto Ground Wire</p>  <p>Key Switch Harness</p>
		<p>Connect the Key Switch Magneto Ground Wire to the Magneto Grounding Stud. The wire is found in the key switch harness on the engine.</p>
	<p>FASTWIRE Low Oil Wire</p>  <p>Low Oil Pressure switch</p>	<p>Engine Controls Low Oil Wire</p> 
		<p>Disconnect the FASTWIRE Low Oil Wire (yellow) and connect the Engine Controls Low Oil Wire (white). Secure the remaining wire.</p>
<p style="writing-mode: vertical-rl; transform: rotate(180deg);">HONDA GX630 21 HP</p>	<p>FASTWIRE Low Oil Wire</p>  <p>Low Oil Pressure switch</p> <p>Engine Controls Low Oil Wire</p>	<p>Engine Controls Low Oil Wire</p> 
	<p>Disconnect the FASTWIRE Low Oil Wire from the Low Oil Pressure Switch and connect the Engine Controls Low Oil Wire. Secure the remaining wires.</p>	





WIRING FOR DIESEL PUMP

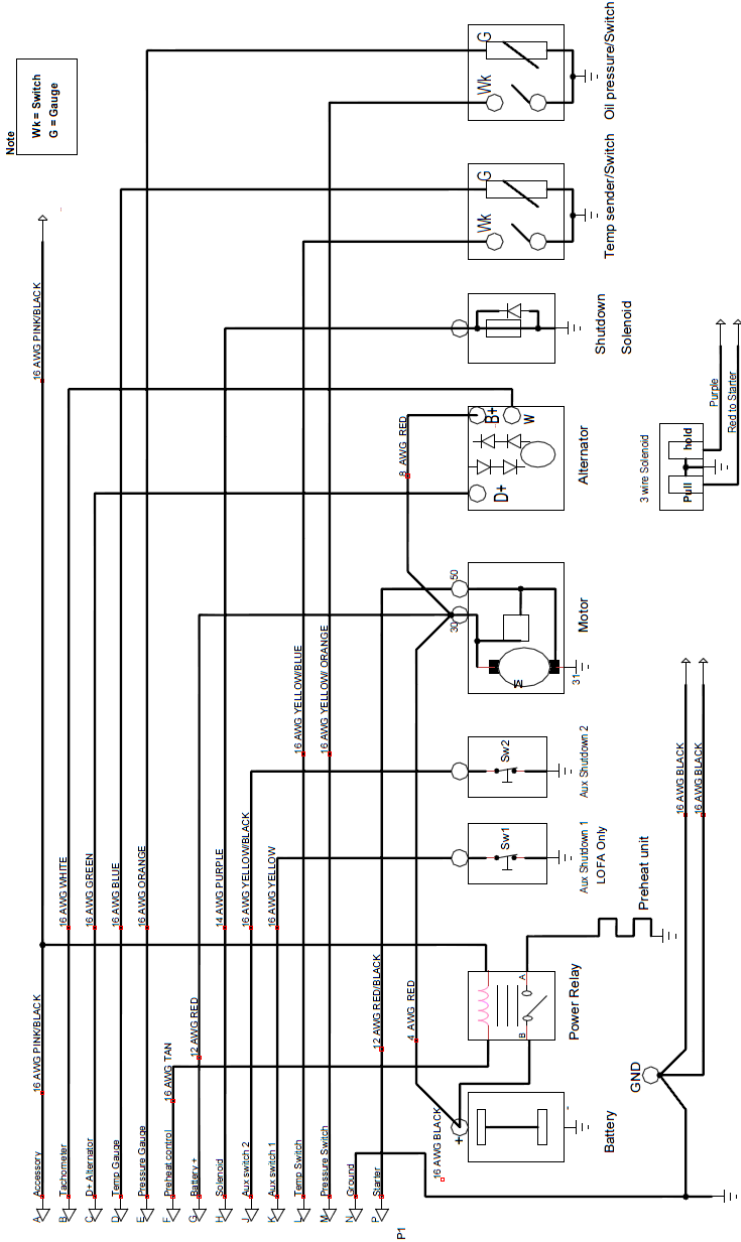

## PUMP END TECHNICAL DATA

### Threads

Discharge port	2-1/2" [63.5 mm] NPT Female / 3" [76.2 mm] Victaulic Combination
Suction (intake) port	3" [76.2 mm] NPT Female / 4" [101.6 mm] Victaulic Combination

### Torque Values

Retaining ring screw	22-25 in-lbs.	2.5-2.8 Nm
Suction cover screw	32-36 in-lbs.	3.6-4.1 Nm
Lock nut 12-50	250-260 in-lbs.	28-29 Nm

### Clearance Data and Limits

Impeller outside diameter	3.980-4.005 in	101.09-101.73 mm
Impeller bore	0.626-0.629 in	15.90-15.98 mm
Pump body (volute) ball bearing housing bore	2.047-2.049 in	51.994-52.045 mm
Pump body (volute) mechanical rotary seal housing bore	1.875-1.878 in	45.63-47.70 mm
Suction cover sleeve bearing bore	0.5934-0.5942 in	15.072-15.093 mm
Shaft ball bearing diameter	0.9844-0.9847 in	25.004-25.011 mm
Shaft sleeve bearing diameter	0.4965-0.4992 in	12.611-12.680 mm
Shaft maximum run-out	0.0035 in	0.089 mm
Sleeve bearing bore	0.500-0.503 in	12.70-12.78 mm









# WARRANTY

**WHEREAS** subject to the following general and specific terms and conditions, WATERAX Inc. (the “**Seller**”) hereby warrants to the original purchaser of the products from WATERAX, (the “**Purchaser**”) that its products, including any pump parts products manufactured by WATERAX (the “**Products**”) sold under Seller’s brands will be free of defects in material and workmanship for the applicable Warranty Period (as set out in full at [www.waterax.com/eng/warranty](http://www.waterax.com/eng/warranty)).

Product	Warranty Period	Coverage
4-Stroke Powered Pumps	Two (2) Years	Limited
2-Stroke Powered Pumps	Earlier of Two (2) Years or One hundred (100) run hours	Limited
Control Panels, Electronics, Manifolds	One (1) Year	Limited
Genuine Parts	Ninety (90) Days	Limited

**1. Limitations, exclusions and other terms and conditions applicable for all Products:**

- a. The Warranty shall be voided upon the occurrence of any of the following events: (a) the Product is used for an application, with products or in a manner other than the application, products and manner for which such Product is designed and intended; (b) the Product is subjected to a use, service, condition or environment other than a use, service, condition or environment for which such Product is designed and intended; (c) the Product is not properly installed by the Purchaser or its agent or representative; (d) the Product is not properly tested and maintained in accordance with Seller’s product manuals and supplemental instructions and guidelines, applicable industry standards and guidelines, and applicable legal and regulatory requirements; (e) the Product is altered, modified, serviced (with the exception of routine maintenance performed in accordance with the Seller’s product manuals and supplemental instructions as set out in full at [www.waterax.com/eng/warranty](http://www.waterax.com/eng/warranty), and industry accepted standards and guidelines), or repaired by a person other than the Seller or a person authorized by the Seller to make such alteration or modification or perform such service or repair; (f) the Seller is not paid the full amount of the purchase price for the Product when due; (g) any bad faith invocation of a warranty claim or breach of a purchase agreement by the Purchaser.
- b. The following are excluded from Warranty coverage: (a) non-defective parts worn, exhausted or consumed through normal usage of the Product; (b) any consumable parts normally subject to routine replacement, including but not limited to pump packing, O- rings, gaskets, intake screens, anodes or filters; (c) routine maintenance as specified and in accordance with the Seller’s product manuals and supplemental instructions and guidelines as set out in full at [www.waterax.com/eng/warranty](http://www.waterax.com/eng/warranty); (d) failure due to compliance with a specification or design provided or required by Purchaser; (e) failure due to improper operation, excess pressure, excess voltage, abuse, misuse, negligence or accidents or other similar causes; (f) failure due to operator error; (g) damage during or after shipment and failure attributable thereto or resulting there from; (h) failure attributable to or resulting from the failure or substandard, inadequate or improper performance of any part, component or equipment not supplied by the Seller; (i) failure attributable to or resulting from the failure or substandard, inadequate or improper performance of any third party part, component, product or equipment, whether or not combined, packaged, incorporated, installed or used with a Seller brand part, component, product or equipment.

2. **Claim Procedure.** The claim procedure applicable under this warranty, including any applicable notice and documentation requirements, are set out in full at [www.waterax.com/eng/warranty](http://www.waterax.com/eng/warranty) and constitute an essential term of this Warranty.

3. **Repaired and Replacement Product.** If requested to do so by the Purchaser the Seller may, at its sole option and in its sole discretion, supply a replacement Product or part to the Purchaser prior to making a final determination as to whether Warranty Coverage is available.

If the Seller ultimately determines that no Warranty Coverage is available for a Product claimed to be defective, the Purchaser shall have the option of either (a) having the Product returned to it freight collect without repair or replacement; or (b) if Seller determines that the Product is repairable, have the Product repaired by Seller or another party designated by it on a time and materials basis at Seller’s then current standard charges for non-warranty repairs and then returned to Purchaser freight collect. The Seller reserves the right to use reconditioned parts for Warranty repairs and to use reconditioned Products for Warranty replacements. Repaired Product and replacement Product shall be warranted only for the remainder of the original Warranty Period.

4. **Limitation of Liability:** SELLER’S WARRANTY AS SET FORTH HEREIN IS SELLER’S SOLE AND EXCLUSIVE WARRANTY AND IS IN LIEU OF ALL OTHER WARRANTIES, EXPRESS OR IMPLIED, INCLUDING, BUT NOT LIMITED TO, ALL WARRANTIES OF MERCHANTABILITY, QUALITY, COURSE OF DEALING, USAGE OF TRADE, FITNESS FOR A PARTICULAR PURPOSE AND NON-INFRINGEMENT. THE RIGHTS AND REMEDIES SET FORTH HEREIN ARE THE SOLE AND EXCLUSIVE RIGHTS AND REMEDIES AGAINST SELLER, EXCEPT FOR THE SPECIFIC LIABILITIES AND OBLIGATIONS PROVIDED HEREIN, SELLER SHALL HAVE NO LIABILITY OR OBLIGATION WITH RESPECT TO ANY PRODUCT CLAIMED TO BE DEFECTIVE IN ANY MANNER



# **WATERAX**

All information contained in this document including drawings is proprietary to WATERAX and may not be copied, reproduced or used in whole or in part without our prior written permission. The information in this document is subject to change without notice. Model displayed with multiple options. Weight and dimensions are approximated and may vary depending on options.

## **WATERAX INC.**

6635 Henri-Bourassa W.  
Montreal, QC H4R 1E1

T 514 637-1818

F 514 637-3985

TF 1 855 616-1818

[info@waterax.com](mailto:info@waterax.com)

**waterax.com**

To help you stay **#ReadyForWildfires**, we've made a few changes, placing 100% of our focus on manufacturing our core products, portable fire pumps.

To do so, we've established a network of trusted supply and distribution partners that can help us provide *WATERAX* pumps quickly in addition to water-handling equipment and accessories.

For immediate assistance when it comes to pumps and water-handling accessories, please [contact your local dealer](#).

For genuine spare parts, visit our [online store](#).

